

Future Technology Devices International Ltd.

FT122

(Enhanced USB Device Controller with Parallel Bus IC)

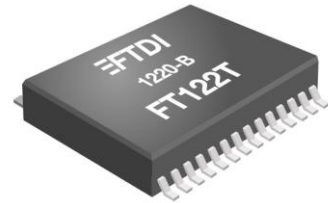

The FT122 is a USB generic interface controller with the following advanced features:

- USB 2.0 Full Speed compatible
- High performance USB device controller with integrated SIE, endpoint buffer, transceiver and voltage regulators
- Fully integrated clock generation with no external crystal required
- Supports 8-bit parallel interface to external microcontroller
- Supports DMA operation
- Supports up to 8 bi-directional endpoints with total 2K bytes endpoint buffer
- Max packet size is 504 bytes for isochronous endpoint and 64 bytes for control/bulk/interrupt endpoint
- Double buffer scheme for any endpoint increases data transfer throughput
- Multiple interrupt modes to facilitate both bulk and isochronous transfers
- USB Battery Charger detection allowing optimized charging profile
- Dedicated clock output pin with programmable clock frequency (4 – 24 MHz)
- 30 kHz output clock provided during suspend
- Integrated DP pull-up resistor for USB connection
- USB connection indicator that toggles with USB transmit and receive activities
- Supports bus powered or self powered application
- VCC power supply operation at 3.3V or 5V
- Internal 1.8V and 3.3V LDO regulators
- VCC IO level range from 1.8V to 3.3V
- Integrated power-on-reset circuit
- UHCI/OHCI/EHCI host controller compatible
- -40°C to 85°C extended operating temperature range
- Available in Pb-free TSSOP-28 and QFN-28 packages (RoHS compliant)

Neither the whole nor any part of the information contained in, or the product described in this manual, may be adapted or reproduced in any material or electronic form without the prior written consent of the copyright holder. This product and its documentation are supplied on an as-is basis and no warranty as to their suitability for any particular purpose is either made or implied. Future Technology Devices International Ltd will not accept any claim for damages howsoever arising as a result of use or failure of this product. Your statutory rights are not affected. This product or any variant of it is not intended for use in any medical appliance, device or system in which the failure of the product might reasonably be expected to result in personal injury. This document provides preliminary information that may be subject to change without notice. No freedom to use patents or other intellectual property rights is implied by the publication of this document. Future Technology Devices International Ltd, Unit 1, 2 Seaward Place, Centurion Business Park, Glasgow G41 1HH United Kingdom. Scotland Registered Company Number: SC136640

1 Typical Applications

- Provide USB port to Microcontrollers
- USB Industrial Control
- Mass storage data transfers for multitude of embedded systems applications, including medical, industrial data-logger, power-metering, and test instrumentation
- Provide USB port to FPGA's
- Utilising USB to add system modularity
- Isochronous support for video applications in security, industrial control, and quality inspections

1.1 Part Numbers

Part Number	Package
FT122T-x	TSSOP-28
FT122Q-x	QFN-28

Note: Packaging codes for x is:

- R: Taped and Reel, (TSSOP is 2,500pcs per reel, QFN is 6,000pcs per reel).
- U: Tube packing, 50pcs per tube (TSSOP only)
- T: Tray packing, 490pcs per tray (QFN only)

For example: FT122T-R is 2,500pcs taped and reel packing

1.2 USB Compliant

At the time of writing this datasheet, the FT122 was in the process of completing USB compliance testing.

2 Block Diagrams

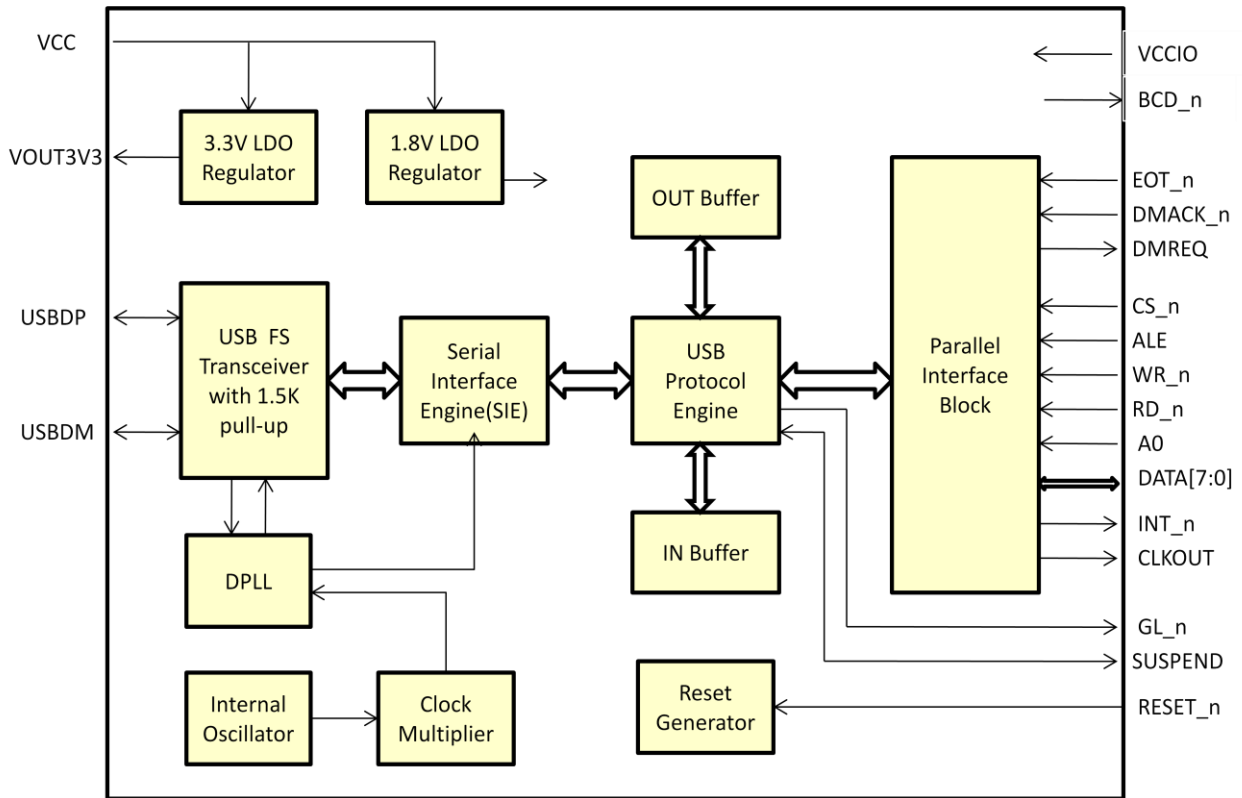

Figure 2-1 FT122 Block Diagram

For a description of each function please refer to Section 4.

Table of Contents

1	Typical Applications.....	2
1.1	Part Numbers.....	2
1.2	USB Compliant	2
2	Block Diagrams	3
3	Device Pin Out and Signal Description	6
3.1	TSSOP-28 Package Pin Out	6
3.2	QFN-28 Package Pin Out.....	6
3.3	Pin Description	7
4	Function Description.....	9
4.1	Functional Block Descriptions	9
4.2	Interrupt Modes.....	10
5	Endpoint Buffer Management	11
5.1	Endpoint Buffer Management in Default Mode	11
5.2	Endpoint Buffer Management in Enhanced Mode	12
6	Commands and Registers	14
6.1	Command Summary.....	14
6.2	Initialization Commands.....	19
6.2.1	Set Address Enable	19
6.2.2	Set Endpoint Enable.....	19
6.2.3	Set Mode	19
6.2.4	Set DMA	21
6.2.5	Set Endpoint Configuration (for Enhanced Mode)	22
6.3	Data Flow Commands	23
6.3.1	Read Interrupt Register	23
6.3.2	Select Endpoint	25
6.3.3	Read Last Transaction Status	25
6.3.4	Read Endpoint Status.....	26
6.3.5	Read Buffer.....	27
6.3.6	Write Buffer	27
6.3.7	Clear Buffer	27
6.3.8	Validate Buffer	28
6.3.9	Set Endpoint Status	28
6.3.10	Acknowledge Setup	28
6.4	General Commands.....	28
6.4.1	Read Current Frame Number.....	29
6.4.2	Send Resume.....	29
6.4.3	Set Buffer Interrupt Mode	29
6.4.4	Read Vendor ID	30



6.4.5	Read Product ID	30
6.4.6	Read FTDI ID	30
6.4.7	Set IO Pad Drive Strength.....	30
7	Application Information	32
8	Devices Characteristics and Ratings	33
8.1	Absolute Maximum Ratings.....	33
8.2	DC Characteristics.....	34
8.3	AC Characteristics.....	35
9	Package Parameters.....	39
9.1	TSSOP-28 Package Dimensions	39
9.2	TSSOP-28 Package Markings	40
9.3	QFN-28 Package Dimensions	41
9.4	QFN-28 Package Markings	42
9.5	Solder Reflow Profile	42
10	Contact Information	44
	Appendix A– References	45
	Appendix B - List of Figures and Tables	45
	Appendix C - Revision History.....	47

3 Device Pin Out and Signal Description

3.1 TSSOP-28 Package Pin Out

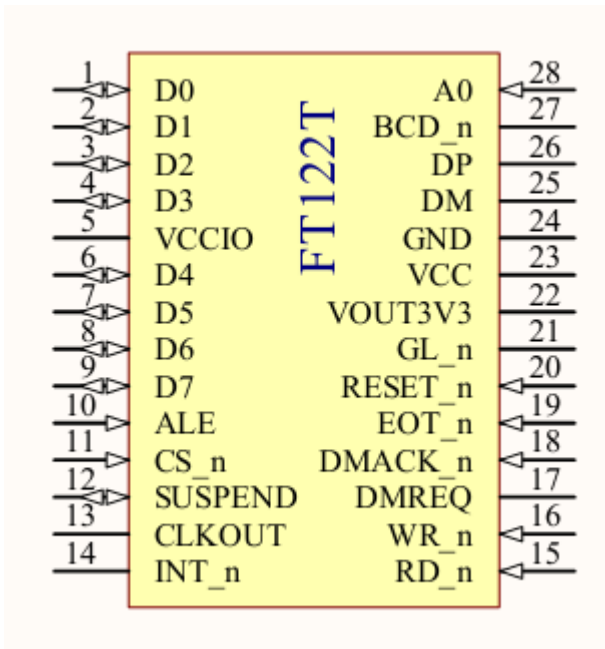

Figure 3-1 TSSOP-28 package schematic symbol

3.2 QFN-28 Package Pin Out

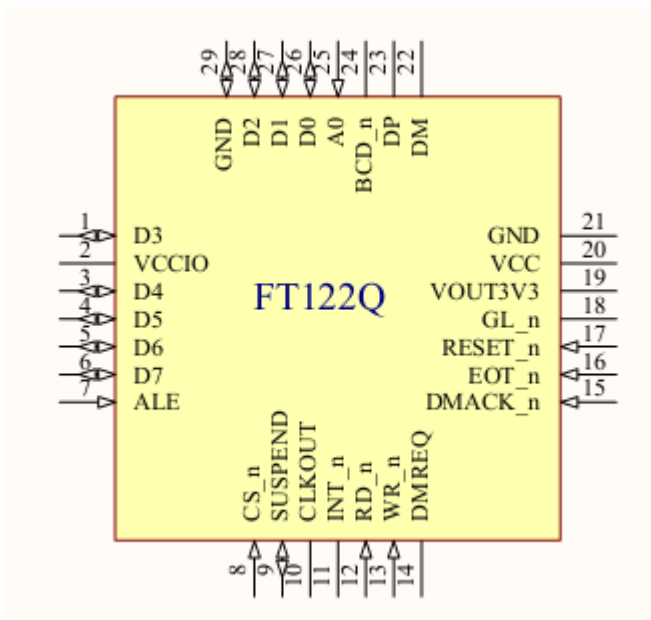

Figure 3-2 QFN-28 package schematic symbol

3.3 Pin Description

PIN No. (TSSOP- 28)	PIN No. (QFN- 28)	PIN NAME	TYPE	DESCRIPTION
1	26	D0	IO	Data bus bit 0.
2	27	D1	IO	Data bus bit 1.
3	28	D2	IO	Data bus bit 2.
4	1	D3	IO	Data bus bit 3.
5	2	VCCIO	P	IO Supply Voltage; 1.8V, 2.5V or 3.3V
6	3	D4	IO	Data bus bit 4.
7	4	D5	IO	Data bus bit 5.
8	5	D6	IO	Data bus bit 6.
9	6	D7	IO	Data bus bit 7.
10	7	ALE	I	Address latch enable for multiplexed address/data bus configuration. This pin must be pulled Low for non-multiplexed address/data bus configuration.
11	8	CS_n	I	Chip select (Active Low).
12	9	SUSPEND	I,OD	Device suspend (output) and wakeup (input).
13	10	CLKOUT	O	Programmable output clock.
14	11	INT_n	OD	Interrupt (Active Low).
15	12	RD_n	I	Read enable (Active Low).
16	13	WR_n	I	Write enable (Active Low).
17	14	DMREQ	O	DMA request.
18	15	DMACK_n	I	DMA acknowledge (Active Low).
19	16	EOT_n	I	End of DMA transfer (Active Low). Also function as Vbus sensing input for self-powered application.
20	17	RESET_n	I	Asynchronous reset (Active Low).
21	18	GL_n	OD	USB bus activity indicator (Active Low)
22	19	VOUT3V3	P	3.3V regulator output for 5V operation; To operate the IC at 3.3 V, supply 3.3 V to both the VCC and VOUT3V3 pins

PIN No. (TSSOP-28)	PIN No. (QFN-28)	PIN NAME	TYPE	DESCRIPTION
23	20	VCC	P	Power supply (3.3V or 5V)
24	21	GND	P	Ground
25	22	DM	AIO	USB data signal minus
26	23	DP	AIO	USB data signal plus
27	24	BCD_n	O	USB Charger detector output
28	25	A0	I	Address bit for non-multiplexed address/data bus configuration. - A0=1 indicates command phase; - A0=0 indicates data phase. This pin must be pulled High for multiplexed address/data bus configuration.
-	29	GND	P	Ground. Die pad for QFN-28 package.

Table 3-1 FT122 Pin Description

Note: a) Pin name with suffix "_n" denotes active low input/output signal.

b) Symbol used for pin TYPE:

OD : Open Drain Output

O : Output

IO : Bi-directional Input and Output

I : Plain input

AIO : Analog Input and Output

P : Power or ground

4 Function Description

The FT122 is a USB device controller which interfaces with microcontrollers via a generic 8-bit parallel bus.

4.1 Functional Block Descriptions

The following sections describe the function of each block. Please refer to the block diagram shown in **Figure 2-1**.

+1.8V LDO Regulator. The +1.8V LDO regulator generates the +1.8V reference voltage for the internal core of the IC with input capabilities from 3.3V or 5V.

+3.3V LDO Regulator. The +3.3V LDO regulator generates the +3.3V supply voltage for the USB transceiver. An external decoupling capacitor needs to be attached to the VOUT3V3 regulator output pin. The regulator also provides +3.3V power to the 1.5k Ω internal pull up resistor on DP pin. The allowable input voltages are 5V or 3.3V. When using 3.3V voltage as input voltage, the VCC and VOUT3V3 pins should be tied together. This will result in the regulator being by-passed.

USB Transceiver. The USB Transceiver cell provides the USB 1.1 / USB 2.0 full-speed physical interface. Output drivers provide +3.3V level slew rate control, while a differential input and two single ended input receivers provide data in, Single-Ended-0 (SE0) and USB reset detection conditions respectfully. A 1.5k Ω pull up resistor on DP is incorporated.

DPLL. The DPLL cell locks on to the incoming NRZI USB data and generates recovered clock and data signals..

Internal Oscillator. The Internal Oscillator cell generates a reference clock. This provides an input to the Clock Multiplier function.

Clock Multiplier. The 12MHz and 48MHz reference clock signals for various internal blocks can be generated from the reference clock via the oscillator functions and clock multiplier circuitry.

Serial Interface Engine (SIE). The Serial Interface Engine (SIE) block performs the parallel to serial and serial to parallel conversion of the USB data. In accordance with the USB 2.0 specification, it performs bit stuffing/un-stuffing and CRC5/CRC16 generation. It also checks the CRC on the USB data stream.

USB Protocol Engine. The USB Protocol Engine manages the data stream from the device USB control endpoint. It handles the low level USB protocol requests generated by the USB host controller. The Protocol Engine also includes a memory management unit which handles endpoint buffers.

OUT Buffer. Data sent from the USB host controller to FT122 via the USB data OUT endpoint is stored in the OUT buffer. Data is removed from the OUT buffer to system memory under control of the parallel interface block.

IN Buffer. Data from system memory is stored in the IN buffer. The USB host controller removes data from the IN buffer by sending a USB request for data from the device data IN endpoint.

RESET Generator. The integrated Reset Generator cell provides a reliable power-on reset to the device internal circuitry at power up. The RESET_n input pin allows an external device to reset the FT122.

Parallel Interface Block. The 8-bit parallel bus allows direct interface to a generic microcontroller (MCU), supporting both multiplexed and non-multiplexed address/data bus configurations. The FT122 also supports Direct Memory Access (DMA) operation. With DMA access data can be written to the IN buffer or read from the OUT buffer without MCU intervention. The DMA access can be done in single cycle or burst mode.

4.2 Interrupt Modes

The FT122 interrupt pin (INT_n) can be programmed to generate an interrupt in different modes. The interrupt source can be any bit in the Interrupt Register, or receiving SOF packet, or both. The interrupt modes are selectable by two register bits, one is the SOF-only Interrupt Mode bit (bit 7 of Clock Division Factor register), and the other is Interrupt Pin Mode bit (bit 5 of DMA Configuration register).

Interrupt mode	Bit SOF-only Interrupt Mode	Bit Interrupt Pin Mode	Interrupt source
0	0	0	Any bit in Interrupt register
1	0	1	Any bit in Interrupt register and SOF
2	1	X	SOF only

Table 4-1 Interrupt modes

5 Endpoint Buffer Management

The FT122 has 2 modes of operation for command and memory management: the default mode (FT120 compatible mode) and the enhanced mode. The buffer management schemes are different in these two modes. Upon reset the default mode is functional. The enhanced mode is activated when any of the Set Endpoint Configuration command (B0h – BFh) is received.

5.1 Endpoint Buffer Management in Default Mode

In default mode the FT122 has 3 bi-directional endpoints (EP0, EP1 and EP2). EP0 is control endpoint, with 16 bytes maximum packet size for both control OUT and control IN endpoint. EP1 can be used as either bulk endpoint or interrupt endpoint, with 16 bytes maximum packet size for both OUT and IN endpoints. Table 5-1 shows the endpoint type and maximum packet size for EP0 and EP1.

Endpoint Number (EP)	Endpoint Index (EPI)	Endpoint Direction	Transfer Type	Max Packet Size
0	0	OUT	Control	16
	1	IN	Control	16
1	2	OUT	Bulk/Interrupt	16
	3	IN	Bulk/Interrupt	16

Table 5-1 Endpoint configuration for EP0 and EP1

EP2 is the primary endpoint. It can be configured as either bulk/interrupt or isochronous endpoint. The maximum packet size allowed for EP2 depends on the mode of configuration through Set Mode command. Table 5-2 shows all the 4 endpoint configuration modes for EP2.

EP2 Endpoint Configuration Mode	Endpoint Index (EPI)	Endpoint Direction	Transfer Type	Max Packet Size
0 (default)	4	OUT	Bulk/Interrupt	64
	5	IN	Bulk/Interrupt	64
1	4	OUT	Isochronous	128
2	5	IN	Isochronous	128
3	4	OUT	Isochronous	64
	5	IN	Isochronous	64

Table 5-2 Endpoint configuration for EP2

As the primary endpoint, EP2 is suitable for transmitting or receiving relatively large data. To improve the data throughput, EP2 is implemented with double buffering. This allows the concurrent operation between USB bus access and MCU or DMA local bus access. For example, for EP2 IN endpoint (EPI5), the USB host can read data from FT122 Buffer 0 while the local MCU is writing to Buffer 1 at the same time. The USB host can subsequently read from FT122 Buffer 1 without waiting for it to be filled. Buffer switching is handled automatically by the FT122.

The EP2 buffer also supports DMA operation. The MCU needs to initialize the DMA operation through Set DMA command. Once DMA operation is enabled, data will be moving between the system memory and FT122 endpoint buffer under the DMA controller. Buffer switching between Buffer 0 and Buffer 1 is handled automatically.

5.2 Endpoint Buffer Management in Enhanced Mode

In enhanced mode the FT122 supports a dedicated 1kB buffer for IN packets and a dedicated 1kB buffer for OUT packets. The OUT/IN buffer can be allocated to any endpoint with the same direction, up to a maximum of 504 bytes double buffered (1008 bytes in total) to one endpoint. 504 is the maximum byte count as there are 1024 bytes in total per OUT/IN Buffer and 8 bytes for IN and OUT packets on control endpoint 0 must always be reserved. Control, interrupt and bulk endpoints can have a maximum packet size of 64 bytes and only isochronous endpoints can be allocated more than 64 bytes.

Isochronous modes can have larger buffer sizes as USB packets can be larger than 64 bytes for isochronous transfer. The isochronous buffer is managed in the same way as bulk, interrupt and control buffers – i.e. a buffer is for one USB packet only and will not span more than one USB packet.

An example of buffer configurations follows, where Configuration 1 and 2 have larger isochronous buffers.

	Configuration 0		Configuration 1		Configuration 2	
	EP	Buffer	EP	Buffer	EP	Buffer
Each cell indicates a 64 byte block	7	1	7	1	5 (ISO)	1
	7	0	(ISO)			
	6	1	7	0		
	6	0	(ISO)			
	5	1	6	1		
	5	0	6	0		
	4	1	2	1	5 (ISO)	0
	4	0	2	0		
	3	1	1 (ISO)	1		
	3	0				
	2	1				
	2	0	1 (ISO)	0		
	1	1				
	1	0				
	0	1	0	1	0	1
	0	0	0	0	0	0

Table 5-3 - Example buffer configuration

The endpoint buffer configurations, settable using the Set Endpoint Configuration command, are as follows:

Endpoint buffer size register setting (0b')	Non-isochronous endpoint	Isochronous endpoint
0000	8 bytes	16 bytes
0001	16 bytes	32 bytes
0010	32 bytes	48 bytes
0011	64 bytes	64 bytes
0100	-	96 bytes
0101	-	128 bytes
0110	-	160 bytes
0111	-	192 bytes
1000	-	256 bytes
1001	-	320 bytes
1010	-	384 bytes
1011	-	504 bytes
1100-1111	-	-

Table 5-4 - Endpoint Maximum Packet Size

Note: 504 is the maximum byte count as there are 1024 bytes in total and 8 bytes IN and OUT packets for control endpoint 0 must always be reserved.

6 Commands and Registers

The FT122 supports two command sets: a default command set (Table 6-1) and an enhanced command set (Table 6-2). The enhanced command set is activated if any of the Set Endpoint Configuration commands (0xB0-0xBF) are received by the FT122. Otherwise, the default command set shall be valid.

6.1 Command Summary

Command Name	Target	Code (hex)	Data phase
Initialization Commands			
Set Address Enable	Device	D0h	Write 1 byte
Set Endpoint Enable	Device	D8h	Write 1 byte
Set Mode	Device	F3h	Write 2 bytes
Set DMA	Device	FBh	Write/Read 1 byte
Data Flow Commands			
Read Interrupt Register	Device	F4h	Read 2 bytes
Select Endpoint	Endpoint 0 OUT	00h	Read 1 byte (optional)
	Endpoint 0 IN	01h	Read 1 byte (optional)
	Endpoint 1 OUT	02h	Read 1 byte (optional)
	Endpoint 1 IN	03h	Read 1 byte (optional)
	Endpoint 2 OUT	04h	Read 1 byte (optional)
	Endpoint 2 IN	05h	Read 1 byte (optional)
Read Last Transaction Status	Endpoint 0 OUT	40h	Read 1 byte
	Endpoint 0 IN	41h	Read 1 byte
	Endpoint 1 OUT	42h	Read 1 byte
	Endpoint 1 IN	43h	Read 1 byte
	Endpoint 2 OUT	44h	Read 1 byte
	Endpoint 2 IN	45h	Read 1 byte
Read Endpoint Status	Endpoint 0 OUT	80h	Read 1 byte
	Endpoint 0 IN	81h	Read 1 byte
	Endpoint 1 OUT	82h	Read 1 byte
	Endpoint 1 IN	83h	Read 1 byte
	Endpoint 2 OUT	84h	Read 1 byte

Command Name	Target	Code (hex)	Data phase
	Endpoint 2 IN	85h	Read 1 byte
Read Buffer	Selected Endpoint	F0h	Read multiple bytes
Write Buffer	Selected Endpoint	F0h	Write multiple bytes
Set Endpoint Status	Endpoint 0 OUT	40h	Write 1 byte
	Endpoint 0 IN	41h	Write 1 byte
	Endpoint 1 OUT	42h	Write 1 byte
	Endpoint 1 IN	43h	Write 1 byte
	Endpoint 2 OUT	44h	Write 1 byte
	Endpoint 2 IN	45h	Write 1 byte
Acknowledge Setup	Selected Endpoint	F1h	None
Clear Buffer	Selected Endpoint	F2h	None
Validate Buffer	Selected Endpoint	FAh	None
General Commands			
Read Current Frame Number	Device	F5h	Read 1 or 2 bytes
Send Resume	Device	F6h	None

Table 6-1 FT122 default command set

Command Name	Target	Code (hex)	Data phase
Initialization Commands			
Set Address Enable	Device	D0h	Write 1 byte
Set Endpoint Enable	Device	D8h	Write 1 byte
Set Mode	Device	F3h	Write 2 bytes
Set DMA	Device	FBh	Write/Read 2 bytes
Set Endpoint Configuration	Endpoint 0 OUT	B0h	Write 1 byte
	Endpoint 0 IN	B1h	Write 1 byte
	Endpoint 1 OUT	B2h	Write 1 byte
	Endpoint 1 IN	B3h	Write 1 byte
	Endpoint 2 OUT	B4h	Write 1 byte
	Endpoint 2 IN	B5h	Write 1 byte

Command Name	Target	Code (hex)	Data phase
	Endpoint 3 OUT	B6h	Write 1 byte
	Endpoint 3 IN	B7h	Write 1 byte
	Endpoint 4 OUT	B8h	Write 1 byte
	Endpoint 4 IN	B9h	Write 1 byte
	Endpoint 5 OUT	BAh	Write 1 byte
	Endpoint 5 IN	BBh	Write 1 byte
	Endpoint 6 OUT	BCh	Write 1 byte
	Endpoint 6 IN	BDh	Write 1 byte
	Endpoint 7 OUT	BEh	Write 1 byte
Endpoint 7 IN	BFh	Write 1 byte	
Data Flow Commands			
Read Interrupt Register	Device	F4h	Read 1 to 4 bytes
Select Endpoint	Endpoint 0 OUT	00h	Read 1 byte (optional)
	Endpoint 0 IN	01h	Read 1 byte (optional)
	Endpoint 1 OUT	02h	Read 1 byte (optional)
	Endpoint 1 IN	03h	Read 1 byte (optional)
	Endpoint 2 OUT	04h	Read 1 byte (optional)
	Endpoint 2 IN	05h	Read 1 byte (optional)
	Endpoint 3 OUT	06h	Read 1 byte (optional)
	Endpoint 3 IN	07h	Read 1 byte (optional)
	Endpoint 4 OUT	08h	Read 1 byte (optional)
	Endpoint 4 IN	09h	Read 1 byte (optional)
	Endpoint 5 OUT	0Ah	Read 1 byte (optional)
	Endpoint 5 IN	0Bh	Read 1 byte (optional)
	Endpoint 6 OUT	0Ch	Read 1 byte (optional)
	Endpoint 6 IN	0Dh	Read 1 byte (optional)
	Endpoint 7 OUT	0Eh	Read 1 byte (optional)
Endpoint 7 IN	0Fh	Read 1 byte (optional)	
Read Last Transaction Status	Endpoint 0 OUT	40h	Read 1 byte

Command Name	Target	Code (hex)	Data phase
	Endpoint 0 IN	41h	Read 1 byte
	Endpoint 1 OUT	42h	Read 1 byte
	Endpoint 1 IN	43h	Read 1 byte
	Endpoint 2 OUT	44h	Read 1 byte
	Endpoint 2 IN	45h	Read 1 byte
	Endpoint 3 OUT	46h	Read 1 byte
	Endpoint 3 IN	47h	Read 1 byte
	Endpoint 4 OUT	48h	Read 1 byte
	Endpoint 4 IN	49h	Read 1 byte
	Endpoint 5 OUT	4Ah	Read 1 byte
	Endpoint 5 IN	4Bh	Read 1 byte
	Endpoint 6 OUT	4Ch	Read 1 byte
	Endpoint 6 IN	4Dh	Read 1 byte
	Endpoint 7 OUT	4Eh	Read 1 byte
Endpoint 7 IN	4Fh	Read 1 byte	
Read Endpoint Status	Endpoint 0 OUT	80h	Read 1 byte
	Endpoint 0 IN	81h	Read 1 byte
	Endpoint 1 OUT	82h	Read 1 byte
	Endpoint 1 IN	83h	Read 1 byte
	Endpoint 2 OUT	84h	Read 1 byte
	Endpoint 2 IN	85h	Read 1 byte
	Endpoint 3 OUT	86h	Read 1 byte
	Endpoint 3 IN	87h	Read 1 byte
	Endpoint 4 OUT	88h	Read 1 byte
	Endpoint 4 IN	89h	Read 1 byte
	Endpoint 5 OUT	8Ah	Read 1 byte
	Endpoint 5 IN	8Bh	Read 1 byte
	Endpoint 6 OUT	8Ch	Read 1 byte
	Endpoint 6 IN	8Dh	Read 1 byte

Command Name	Target	Code (hex)	Data phase
	Endpoint 7 OUT	8Eh	Read 1 byte
	Endpoint 7 IN	8Fh	Read 1 byte
Read Buffer	Selected Endpoint	F0h	Read n bytes
Write Buffer	Selected Endpoint	F0h	Write n bytes
Set Endpoint Status	Endpoint 0 OUT	40h	Write 1 byte
	Endpoint 0 IN	41h	Write 1 byte
	Endpoint 1 OUT	42h	Write 1 byte
	Endpoint 1 IN	43h	Write 1 byte
	Endpoint 2 OUT	44h	Write 1 byte
	Endpoint 2 IN	45h	Write 1 byte
	Endpoint 3 OUT	46h	Write 1 byte
	Endpoint 3 IN	47h	Write 1 byte
	Endpoint 4 OUT	48h	Write 1 byte
	Endpoint 4 IN	49h	Write 1 byte
	Endpoint 5 OUT	4Ah	Write 1 byte
	Endpoint 5 IN	4Bh	Write 1 byte
	Endpoint 6 OUT	4Ch	Write 1 byte
	Endpoint 6 IN	4Dh	Write 1 byte
	Endpoint 7 OUT	4Eh	Write 1 byte
	Endpoint 7 IN	4Fh	Write 1 byte
Acknowledge Setup	Selected Endpoint	F1h	None
Clear Buffer	Selected Endpoint	F2h	None
Validate Buffer	Selected Endpoint	FAh	None
General Commands			
Send Resume	Device	F6h	None
Read Current Frame Number	Device	F5h	Read 1 or 2 bytes
Set IO Pad Drive Strength	Device	E9h	Write 1 byte
Set Buffer Interrupt Mode	Device	ECh	None

Command Name	Target	Code (hex)	Data phase
Read Vendor ID	Device	EBh	Read 2 bytes
Read Product ID	Device	EAh	Read 2 bytes
Read FTDI ID	Device	EDh	Read 1 byte

Table 6-2 enhanced command set

6.2 Initialization Commands

6.2.1 Set Address Enable

Command : D0h

Data : Write 1 byte

Bit	Symbol	Reset	Description
6-0	Address	0b'0000000	USB assigned device address. A bus reset will reset all address bits to 0.
7	Enable	0	Function enable. A bus reset will automatically enable the function at default address 0.

Table 6-3 Address Enable Register

6.2.2 Set Endpoint Enable

Command : D8h

Data : Write 1 byte

Bit	Symbol	Reset	Description
0	EP_Enable	0	Enable all endpoints (Note EP0 is always enabled regardless the setting of EP_Enable bit). Endpoints can only be enabled when the function is enabled.
7-1	Reserved	0b'0000000	Reserved, write to 0

Table 6-4 Endpoint Enable Register

6.2.3 Set Mode

Command : F3h

Data : Write 2 bytes

Bit	Symbol	Reset	Description
0	Reserved	0	Reserved, write to 0
1	No Suspend Clock	1	0: CLKOUT switches to 30 KHz during USB suspend

Bit	Symbol	Reset	Description
			1: CLKOUT remains unchanged during USB suspend Note: The programmed value will not be changed by a bus reset.
2	Clock Running	1	0: internal clocks stop during USB suspend 1: internal clocks continue running during USB suspend This bit must be set to '0' for bus powered application in order to meet the USB suspend current requirement. Note: The programmed value will not be changed by a bus reset.
3	Interrupt Mode	1	0: interrupt will not generate on NAK or Error transactions 1: interrupt will generate on NAK and Error transactions Note: The programmed value will not be changed by a bus reset.
4	DP_Pullup	0	0: Pullup resistor on DP pin disabled 1: Pullup resistor on DP pin enabled when Vbus is present Note: The programmed value will not be changed by a bus reset.
5	Reserved	0	Reserved, write to 0
7-6	Endpoint Configuration Mode	0b'00	Set the endpoint configuration mode for EP2. 00: Mode 0 (Non-ISO Mode) 01: Mode 1 (ISO-OUT Mode) 10: Mode 2 (ISO-IN Mode) 11: Mode 3 (ISO-IO Mode) In Enhanced Mode, these 2 bits are reserved. The Endpoint Configuration will be done through separate command. See "Set Endpoint Configuration" commands.

Table 6-5 Configuration Register (Byte 1)

Bit	Symbol	Reset	Description
3-0	Clock Division Factor	0b'1011	The Clock Division Factor value (CDF) determines the output clock frequency on the CLKOUT pin. Frequency = 48 MHz / (CDF + 1), where CDF ranges 1-12 or the allowed CLKOUT frequency is 4-24 MHz. Default CLKOUT is 4 MHz. When the CDF is programmed to 0b'1111, the CLKOUT will be turned off. It is recommended to turn off the CLKOUT if it is not used, for power saving (about 3mA). Note: The programmed value will not be changed by a bus reset.

Bit	Symbol	Reset	Description
5-4	Reserved	0b'00	Reserved, write to 0
6	SET_TO_ONE	0	This bit must be set to 1
7	SOF-only Interrupt Mode	0	0: normal operation 1: interrupt will generate on receiving SOF packet only, regardless the value of the Interrupt Pin Mode bit in DMA configuration register.

Table 6-6 Clock Division Factor Register (Byte 2)

6.2.4 Set DMA

Command : FBh

Data : Read/Write 1 byte; Read/Write 2 bytes (for Enhanced Mode)

Bit	Symbol	Reset	Description
1-0	DMA Burst	0b'00	Set the DMA burst size 00: Single cycle mode 01: 4 cycle burst mode 10: 8 cycle burst mode 11: 16 cycle burst mode
2	DMA Enable	0	Enable DMA operation 0: DMA operation is disabled 1: DMA operation is enabled FT122 will clear this bit upon EOT_n assertion.
3	DMA Direction	0	This bit indicates the DMA read or write operation. 0: DMA read. Data read from FT122 OUT buffer to system memory. 1: DMA write. Data write to FT122 IN buffer from system memory.
4	Auto Reload	0	Automatically restart the DMA operation. 0: DMA needs to restart by software 1: DMA will restart automatically after the previous DMA transfer finishes
5	Interrupt Pin Mode	0	0: normal operation. Interrupt will generate if any of the bit in the interrupt register is set. 1: interrupt will generate upon receiving SOF packet or if any of the bit in the interrupt register is set.
6	EPI4 Interrupt Enable	0	Interrupt Enable for endpoint index 4. During DMA operation, EPI4 interrupt should be turned off to avoid un-necessary interrupt service. For enhanced mode this bit has no function. EPI4 interrupt is always enabled unless it is selected as a DMA

Bit	Symbol	Reset	Description
			endpoint.
7	EPI5 Interrupt Enable	0	<p>Interrupt Enable for endpoint index 5. During DMA operation, EPI5 interrupt should be turned off to avoid un-necessary interrupt service.</p> <p>For enhanced mode this bit has no function. EPI5 interrupt is always enabled unless it is selected as a DMA endpoint.</p>

Table 6-7 DMA Configuration Register (Byte 1)

Bit	Symbol	Reset	Description
3-0	DMA Endpoint Index	0b'0000	Select the endpoint index number for DMA operation. DMA operation occurs between the selected endpoint buffer and the DMA agent. Any of the 16 endpoint index can be selected for DMA data transfers, but only one at a time.
7-4	Reserved	0b'0000	Reserved, write to 0

Table 6-8 DMA Endpoint Select Register (Byte 2, for Enhanced Mode)

6.2.5 Set Endpoint Configuration (for Enhanced Mode)

Command : B0-BFh

Data : Write 1 byte

Bit	Symbol	Reset	Description
0	Endpoint Enabled	0	Enable or disable the endpoint index associated with the command
2-1	Endpoint Type	0b'00	<p>Endpoint type</p> <p>00: control</p> <p>01: bulk or interrupt</p> <p>10: isochronous</p> <p>11: reserved</p>
6-3	Max Packet Size	0b'0000	Maximum USB packet size for this endpoint. Defined the IN buffer or OUT buffer size for the endpoint. Refer to Table 5-4 for full details on the buffer configuration.
7	Reserved	0	Reserved, write to 0

Table 6-9 Endpoint Configuration Register

6.3 Data Flow Commands

6.3.1 Read Interrupt Register

Command : F4h

Data : Read 1 or 2 bytes (Default Mode); Read 1-4 bytes (Enhanced Mode)

Bit	Symbol	Reset	Description
0	Endpoint 0 Out	0	Interrupt for endpoint 0 OUT buffer. Cleared by Read Last Transaction Status command.
1	Endpoint 0 In	0	Interrupt for endpoint 0 IN buffer. Cleared by Read Last Transaction Status command.
2	Endpoint 1 Out	0	Interrupt for endpoint 1 OUT buffer. Cleared by Read Last Transaction Status command.
3	Endpoint 1 In	0	Interrupt for endpoint 1 IN buffer. Cleared by Read Last Transaction Status command.
4	Endpoint 2 Out	0	Interrupt for endpoint 2 OUT buffer. Cleared by Read Last Transaction Status command.
5	Endpoint 2 In	0	Interrupt for endpoint 2 IN buffer. Cleared by Read Last Transaction Status command.
6	Bus Reset	0	Interrupt for bus reset. This bit will be cleared after reading.
7	Suspend Change	0	Interrupt for USB bus suspend status change. This bit will be set to '1' when FT122 goes to suspend (missing 3 continuous SOFs) or resumes from suspend. This bit will be cleared after reading.

Table 6-10 Interrupt Register Byte 1

Bit	Symbol	Reset	Description
0	DMA EOT	0	Interrupt for end of DMA transfer. This bit will be cleared after reading.
7-1	Reserved	0b'xxxxxxx	Reserved

Table 6-11 Interrupt Register Byte 2

Bit	Symbol	Reset	Description
0	Endpoint 3 Out	0	Interrupt for endpoint 3 OUT buffer. Cleared by Read Last Transaction Status command.
1	Endpoint 3 In	0	Interrupt for endpoint 3 IN buffer. Cleared by Read Last Transaction Status command.
2	Endpoint 4 Out	0	Interrupt for endpoint 4 OUT buffer. Cleared by Read Last Transaction Status command.

Bit	Symbol	Reset	Description
3	Endpoint 4 In	0	Interrupt for endpoint 4 IN buffer. Cleared by Read Last Transaction Status command.
4	Endpoint 5 Out	0	Interrupt for endpoint 5 OUT buffer. Cleared by Read Last Transaction Status command.
5	Endpoint 5 In	0	Interrupt for endpoint 5 IN buffer. Cleared by Read Last Transaction Status command.
6	Endpoint 6 Out	0	Interrupt for endpoint 6OUT buffer. Cleared by Read Last Transaction Status command.
7	Endpoint 6 In	0	Interrupt for endpoint 6 IN buffer. Cleared by Read Last Transaction Status command.

Table 6-12 Interrupt Register Byte 3 (for Enhanced Mode)

Bit	Symbol	Reset	Description
0	Endpoint 7 Out	0	Interrupt for endpoint 7 OUT buffer. Cleared by Read Last Transaction Status command.
1	Endpoint 7 In	0	Interrupt for endpoint 7 IN buffer. Cleared by Read Last Transaction Status command.
7-2	Reserved	0b'xxxxxx	Reserved

Table 6-13 Interrupt Register Byte 4 (for Enhanced Mode)

6.3.2 Select Endpoint

Command : 00-05h (00-0Fh for Enhanced Mode)

Data : Optional Read 1 byte

Bit	Symbol	Reset	Description
0	Full/Empty	0	0: selected endpoint buffer is empty 1: selected endpoint buffer is full
1	Stall	0	0: selected endpoint is not stalled 1: selected endpoint is stalled
7-2	Reserved	0b'xxxxxx	Reserved

Table 6-14 Endpoint Status Register

6.3.3 Read Last Transaction Status

Command : 40-45h (40-4Fh for Enhanced Mode)

Data : Read 1 byte

Bit	Symbol	Reset	Description
0	Data Receive/Transmit Success	0	0: indicate USB data receive or transmit not OK 1: indicate USB data receive or transmit OK
4-1	Error Code	0b'0000	Refer to Table 6-16
5	Setup Packet	0	0: indicate not a setup packet 1: indicate last received packet has a SETUP token
6	Data 0/1 Packet	0	0: packet has a DATA0 token 1: packet has a DATA1 token
7	Previous Status not Read	0	0: previous transaction status was read 1: previous transaction status was not read

Table 6-15 Endpoint Last Transaction Status Register

Error Code	Result
0000	No error
0001	PID encoding error

Error Code	Result
0010	PID unknown
0011	Unexpected packet
0100	Token CRC error
0101	Data CRC error
0110	Time out error
0111	Reserved
1000	Unexpected EOP
1001	Packet NAKed
1010	Sent stall
1011	Buffer overflow
1101	Bit stuff error
1111	Wrong DATA PID

Table 6-16 Transaction error code

6.3.4 Read Endpoint Status

Command : 80-85h (80-8Fh for Enhanced Mode)

Data : Read 1 byte

Bit	Symbol	Reset	Description
1-0	Reserved	0b'00	Reserved
2	Setup packet	0	0: indicate not a setup packet 1: indicate last received packet has a SETUP token
4-3	Reserved	0b'xx	Reserved
5	Buffer 0 Full	0	0: buffer 0 is not filled up 1: buffer 0 is filled up
6	Buffer 1 Full	0	0: buffer 1 is not filled up 1: buffer 1 is filled up

Bit	Symbol	Reset	Description
7	Endpoint Stalled	0	0: endpoint is not stalled 1: endpoint is stalled

Table 6-17 Endpoint Buffer Status Register

6.3.5 Read Buffer

Command : F0h

Data : Read multiple bytes

The Read Buffer command is used to read the received packet from the selected endpoint OUT buffer.

The data in the endpoint buffer is organized as follows:

byte 0: length of payload packet, MSB(for default mode this byte is ignored)

byte 1: length of payload packet, LSB

byte 2: Payload packet byte 1

byte 3: Payload packet byte 2

...

byte n+1: Payload packet byte n (n = packet length)

For DMA read operation the first two bytes are skipped. Only the payload packet itself will be read and stored in system memory.

6.3.6 Write Buffer

Command : F0h

Data : Write multiple bytes

The Write Buffer command is used to write payload packet to the selected endpoint IN buffer.

The data must be organized in the same way as described in the Read Buffer command. For default mode byte 0 should always be set to 00h.

For DMA write operation the first two bytes are skipped. Only the payload packet itself shall be written to the selected endpoint OUT buffer. Buffer is validated when the max packet size is reached, or when the DMA transfer is terminated by EOT_n (usually the last packet).

6.3.7 Clear Buffer

Command : F2h

Data : None

Followed by Read Buffer command, the Clear Buffer command should be issued after all data has been read out from the endpoint buffer. This is to free the buffer to receive next packet from USB host.

6.3.8 Validate Buffer

Command : FAh

Data : None

Followed by Write Buffer command, the Validate Buffer command should be issued after all data has been written to the endpoint buffer. This is to set the buffer full flag so that the packet can be sent to USB host when IN token arrives.

6.3.9 Set Endpoint Status

Command : 40-45h (40-4Fh for Enhanced Mode)

Data : Write 1 byte

Bit	Symbol	Reset	Description
0	Stall	0	0: Disable the endpoint STALL state. 1: Enable the endpoint STALL state. For EP0 OUT (control OUT endpoint) the STALL state will automatically be cleared by receiving a SETUP packet. When this bit is written to '0', the endpoint will reinitialize. Any data in the endpoint buffer will be flushed away, and the PID for next packet will carry DATA0 flag.
7-1	Reserved	0b'xxxxxxx	Reserved

Table 6-18 Endpoint Control Register

6.3.10 Acknowledge Setup

Command : F1h

Data : None

When receiving a SETUP packet the FT122 will flush the IN buffer and disable the Validate Buffer and Clear Buffer commands for both Control IN and Control OUT endpoints. The MCU shall read and process the SETUP packet, and then issue the Acknowledge Setup command to re-enable the Validate Buffer and Clear Buffer commands. The Acknowledge Setup command must be sent to both Control IN and Control OUT endpoints.

6.4 General Commands

6.4.1 Read Current Frame Number

Command : F5h

Data : Read One or Two Bytes

Bit	Symbol	Reset	Description
7-0	Frame Number LSB	00h	Frame number for last received SOF, byte 1 (least significant byte)

Table 6-19 Frame Number LSB Register

Bit	Symbol	Reset	Description
2-0	Frame Number MSB	0b'000	Frame number for last received SOF, byte 2 (Most significant byte)
7-3	Reserved	0b'00000	Reserved

Table 6-20 Frame Number MSB Register

6.4.2 Send Resume

Command : F6h

Data : None

To perform remote-wakeup when suspended, the MCU needs to issue Send Resume command. The FT122 will send an upstream resume signal for a period of 10 ms. If the clock is not running during suspend, the MCU needs to wakeup FT122 by drive SUSPEND pin to LOW, followed by Send Resume command.

6.4.3 Set Buffer Interrupt Mode

Command : ECh (for Enhanced Mode)

Data : none

The read or write buffer commands can be interrupted, typically by a read interrupt register or read last transaction status command, and can be resumed without having to re-issue a read or write buffer command. When the default command set is in use, a read or write buffer command can be resumed after 2 bytes have been read at a read interrupt command. In this case the FT122 design is primed to resume a read or write buffer command if another command is not issued and a read or write occurs.

For the enhanced command set the read interrupt register command has been extended to read 4 bytes. The FT122 therefore needs to know whether to prime at 2 or 4 bytes. The Set Buffer Interrupt Mode command notifies the FT122 to prime after 4 bytes.

6.4.4 Read Vendor ID

Command : EBh (for Enhanced Mode)

Data : read 2 bytes

Read the 2 bytes Vendor ID. Shall return 0403h.

6.4.5 Read Product ID

Command : EAh (for Enhanced Mode)

Data : read 2 bytes

Read the 2 bytes Product ID. Shall return 6018h.

6.4.6 Read FTDI ID

Command : EDh (for Enhanced Mode)

Data : read 1 byte

Read the 1 byte FTDI ID. Shall return 11h.

6.4.7 Set IO Pad Drive Strength

Command : E9h

Data : Write 1 byte

Bit	Symbol	Reset	Description
1-0	CLKOUT pin	0b'00	00: 4mA 01: 8mA 10: 12mA 11:16mA
3-2	D[7:0] pins	0b'00	00: 4mA 01: 8mA 10: 12mA 11:16mA
5-4	INT_n, SUSPEND, DMREQ pins	0b'00	00: 4mA 01: 8mA 10: 12mA 11:16mA
7-6	GL_n pin	0b'00	00: 4mA 01: 8mA 10: 12mA 11:16mA



Table 6-21 IO Pad Drive Strength Register

7 Application Information

Figure 7-1 shows a reference application circuit for a USB bus-powered application. Figure 7-1 shows a reference application circuit for a USB self-powered application.

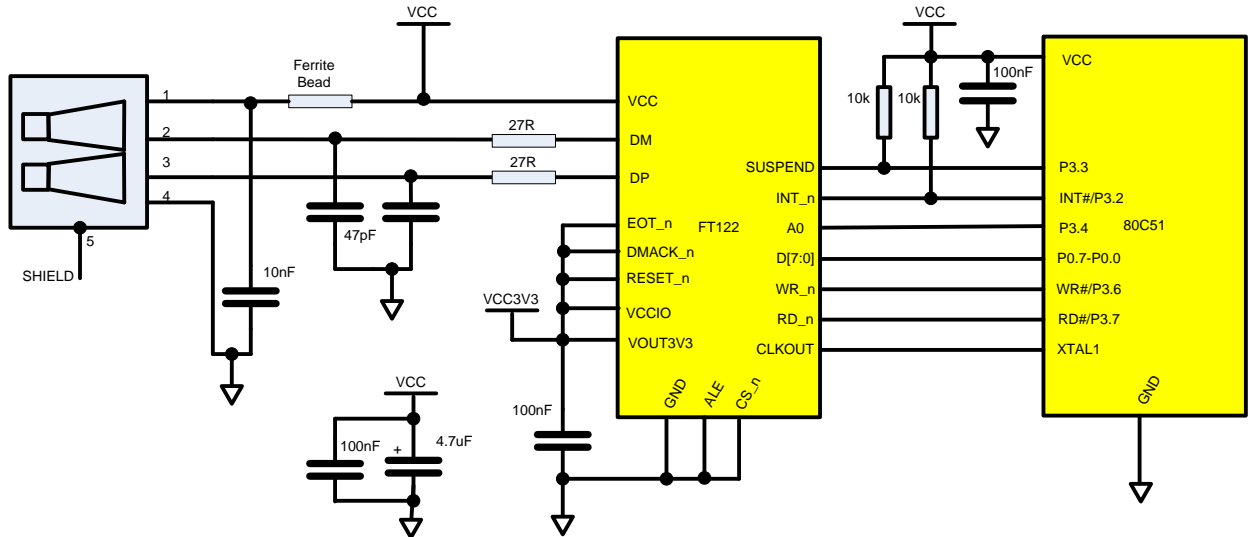

Figure 7-1 FT122 bus powered application

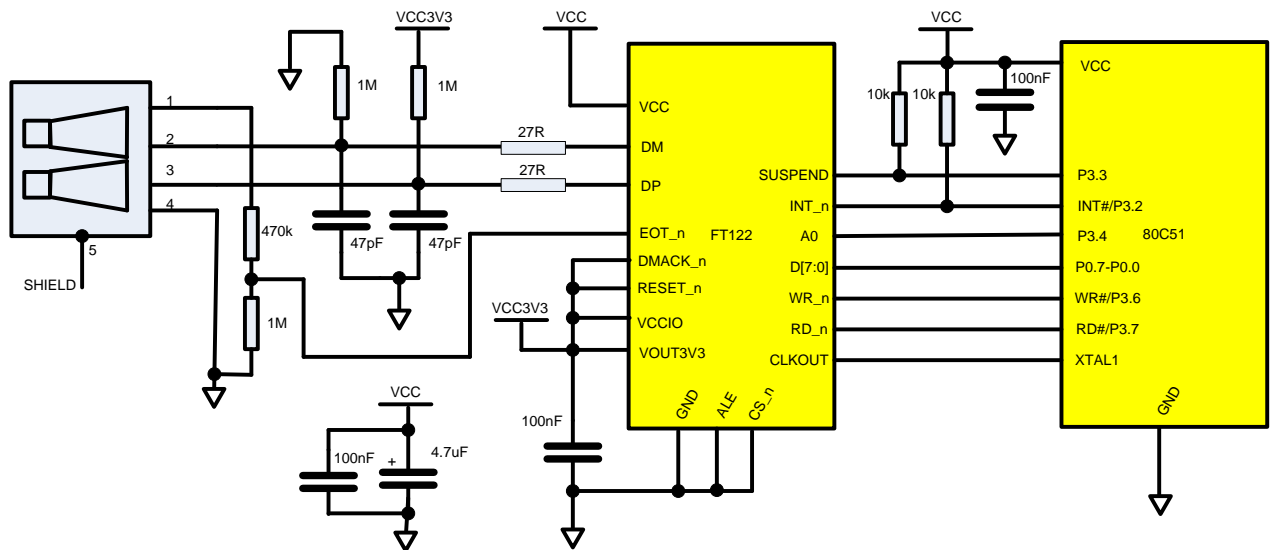

Figure 7-2 FT122 self powered application

8 Devices Characteristics and Ratings

8.1 Absolute Maximum Ratings

The absolute maximum ratings for the FT122 devices are as follows. These are in accordance with the Absolute Maximum Rating System (IEC 60134). Exceeding these may cause permanent damage to the device.

Parameter	Value	Unit
Storage Temperature	-65 to 150	°C
Floor Life (Out of Bag) At Factory Ambient (30°C / 60% Relative Humidity)	168 (IPC/JEDEC J-STD-033A MSL Level 3 Compliant)*	Hours
Ambient Temperature (Power Applied)	-40 to 85	°C
Latch-up current	±200	mA
Electrostatic Discharge Voltage(ESD) human body model(HBM)	±2	kV
Electrostatic Discharge Voltage(ESD) machine model(MM)	±200	V
Electrostatic Discharge Voltage(ESD) charged device model(CDM)	±500	V
VCC Supply Voltage	-0.5 to +6.0	V
DC Input Voltage – DP and USBDM	-0.5 to +3.8	V
DC Input Voltage – High Impedance Bidirectional	-0.5 to + (VCC +0.5)	V
DC Input Voltage – All Other Inputs	-0.5 to + (VCC +0.5)	V
DC Output Current – Outputs	22	mA

Table 8-1 Absolute Maximum Ratings

* If devices are stored out of the packaging beyond this time limit the devices should be baked before use. The devices should be ramped up to a temperature of +125°C and baked for up to 17 hours.

8.2 DC Characteristics

DC Characteristics (Ambient Temperature = -40°C to +85°C).

Parameter	Description	Minimum	Typical	Maximum	Units	Conditions
VCC1	VCC Operating Supply Voltage	4.0	5.0	5.5	V	Normal Operation
VCC2	VCC Operating Supply Voltage	3.0	3.3	3.6	V	Regulator by-pass mode Operation
VCCIO	VCCIO Operating Supply Voltage	1.65		3.6	V	
Icc	Operating Supply Current		3.9		mA	Normal Operation, USB bus transmit or receive
Icc2	Suspend Current		84		μA	USB Suspend, Clock Running = '0', excluding the DP_Pullup current
VOUT3V3	3.3v regulator output	3.0	3.3	3.6	V	VCC=5V

Table 8-2 Operating Voltage and Current

Parameter	Description	Minimum	Typical	Maximum	Units	Conditions
Voh	Output Voltage High	2.9			V	I source = 4mA
Vol	Output Voltage Low			0.4	V	I sink = 4mA
Vih	Input Voltage High	2.0			V	
Vil	Input Voltage Low	-		0.8	V	

Table 8-3 digital I/O Pin Characteristics (VCCIO=+3.3V)

Parameter	Description	Minimum	Typical	Maximum	Units	Conditions
Voh	Output Voltage High	2.25			V	I source = 4mA
Vol	Output Voltage Low			0.4	V	I sink = 4mA
Vih	Input Voltage High	1.7			V	
Vil	Input Voltage Low	-		0.7	V	

Table 8-4 digital I/O Pin Characteristics (VCCIO=+2.5V)

Parameter	Description	Minimum	Typical	Maximum	Units	Conditions
Voh	Output Voltage High	1.62			V	I source = 4mA
Vol	Output Voltage Low			0.4	V	I sink = 4mA
Vih	Input Voltage High	1.17			V	
Vil	Input Voltage Low	-		0.63	V	

Table 8-5 digital I/O Pin Characteristics (VCCIO=+1.8V)

Parameter	Description	Minimum	Typical	Maximum	Units	Conditions
UVoh	I/O Pins Static Output (High)	2.8		3.6	V	R _L = 1.5kΩ to 3.6 V
UVol	I/O Pins Static Output (Low)	-		0.3	V	R _L = 15kΩ to GND
UVse	Single Ended Rx Threshold	0.8		2.0	V	
UCom	Differential Common Mode	0.8		2.5	V	
UVDif	Differential Input Sensitivity	0.2			V	
UDrvZ	Driver Output Impedance	29	-	44	Ω	Including external 22 Ω ±1% series resistor

Table 8-6 USB I/O Pin (DP, USBDM) Characteristics

8.3 AC Characteristics

Symbol	Parameter	VCCIO=3.3V		VCCIO=1.8V		Unit
		Min	Max	Min	Max	
	ALE Timings:					
tLH	ALE High Pulse Width	20		20		ns
tAVLL	Address Valid to ALE Low Time	3		5		ns
tLLAX	ALE Low to Address Transition Time		2		3	ns
	Write Timings:					
tCLWL	CS _n (DMACK _n) Low to WR _n Low Time	0		1		ns
tWHCH	WR _n High to CS _n (DMACK _n) High Time	1		1		ns

Symbol	Parameter	VCCIO=3.3V		VCCIO=1.8V		Unit
		Min	Max	Min	Max	
tAVWL	A0 Valid to WR_n Low Time	0		1		ns
tWHAX	WR_n High to A0 Transition Time	1		1		ns
tWL	WR_n Low Pulse Width	30		30		ns
tWDSU	Write Data Setup Time	5		8		ns
tWDH	Write Data Hold Time	1		1		ns
tWC	Write Cycle Time	40		40		ns
t(WC-WD)	Write command to write data	40		40		ns
	Read Timings:					
tCLRL	CS_n (DMACK_n) Low to RD_n Low Time	0		1		ns
tRHCH	RD_n High to CS_n (DMACK_n) High Time	1		1		ns
tAVRL	A0 Valid to RD_n Low Time	0		1		ns
tRL	RD_n Low Pulse Width	30		30		ns
tRLDD	RD_n Low to Data Valid Time		25		25	ns
tRHDZ	RD_n High to Data Hi-Z Time		20		20	ns
tRHNDV	RD_n High to Next Data Valid Time		40		50	ns
tRC	Read Cycle Time	40		50		ns
t(WC-RD)	Write command to read data	40		50		ns

Table 8-7 Parallel Interface IO timing

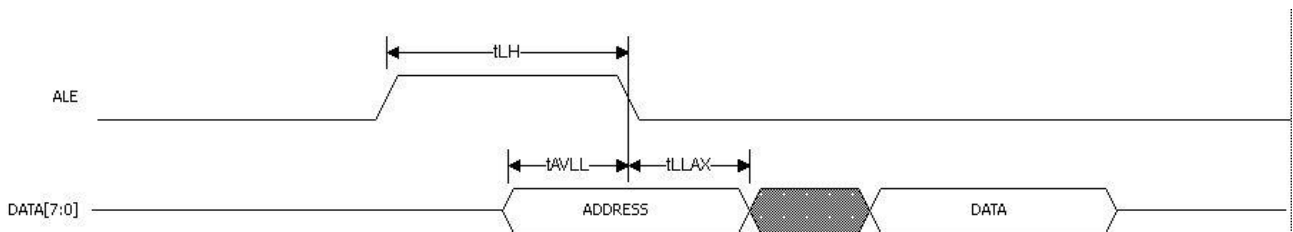

Figure 8-1 ALE Timing

Symbol	Parameter	VCCIO=3.3V		VCCIO=1.8V		Unit
		Min	Max	Min	Max	
tELRL	EOT_n Low to DMREQ Low Time		40		40	ns

Table 8-8 DMA timing characteristics

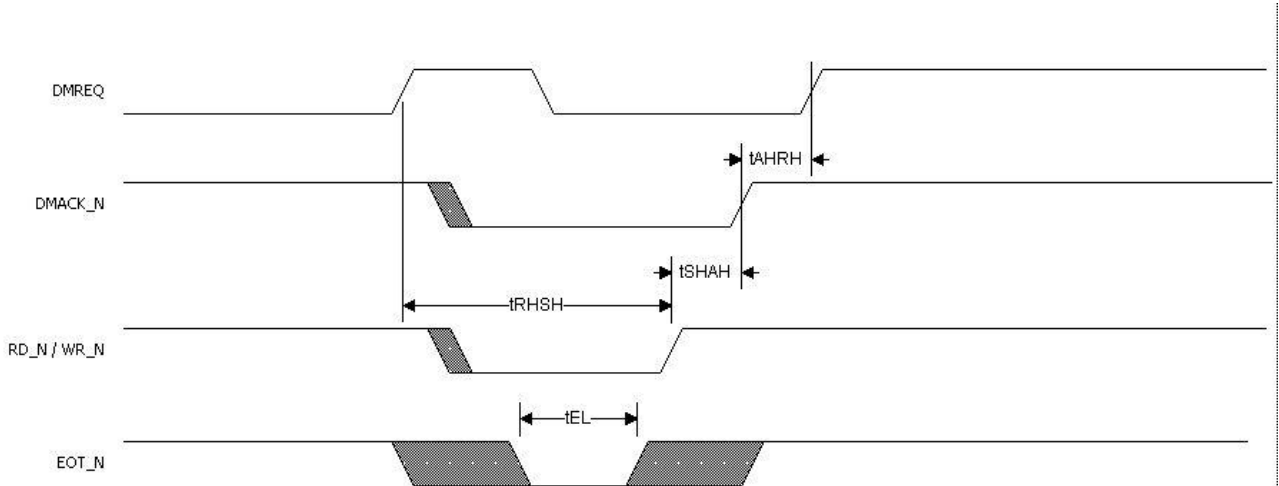

Figure 8-3 Single cycle DMA timing

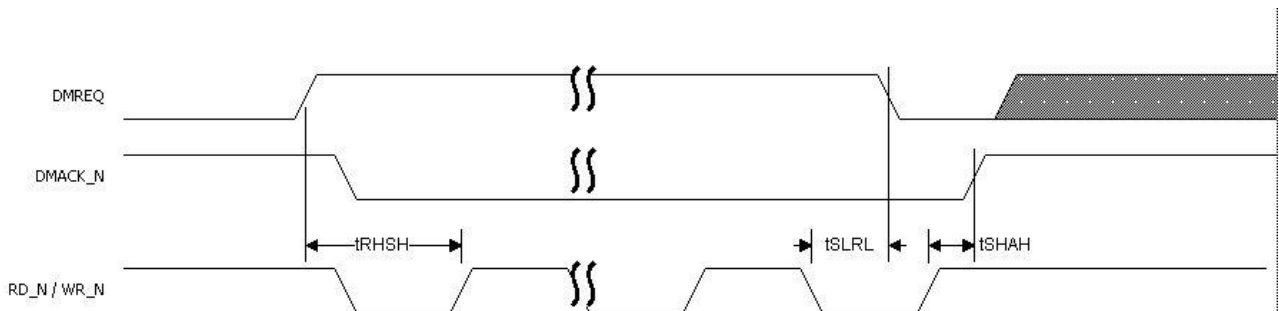

Figure 8-4 Burst mode DMA timing

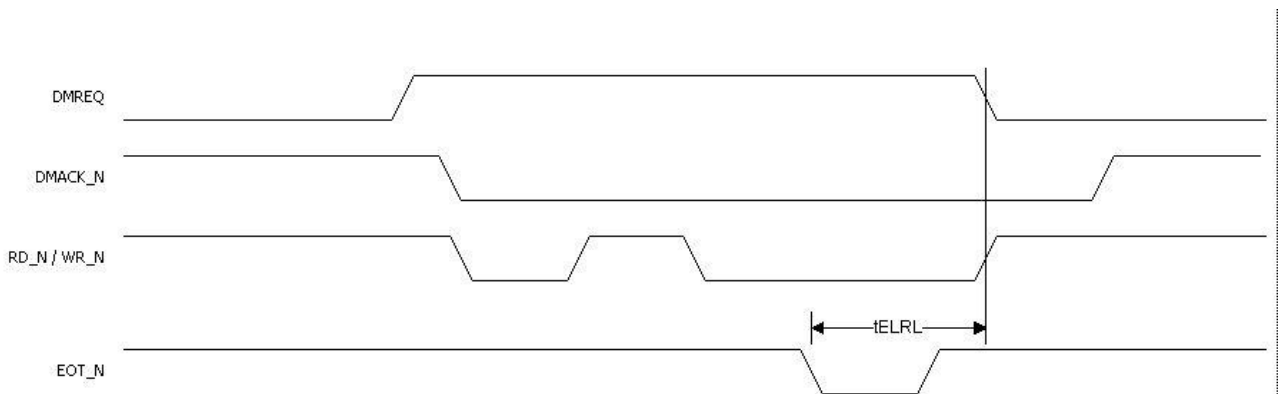
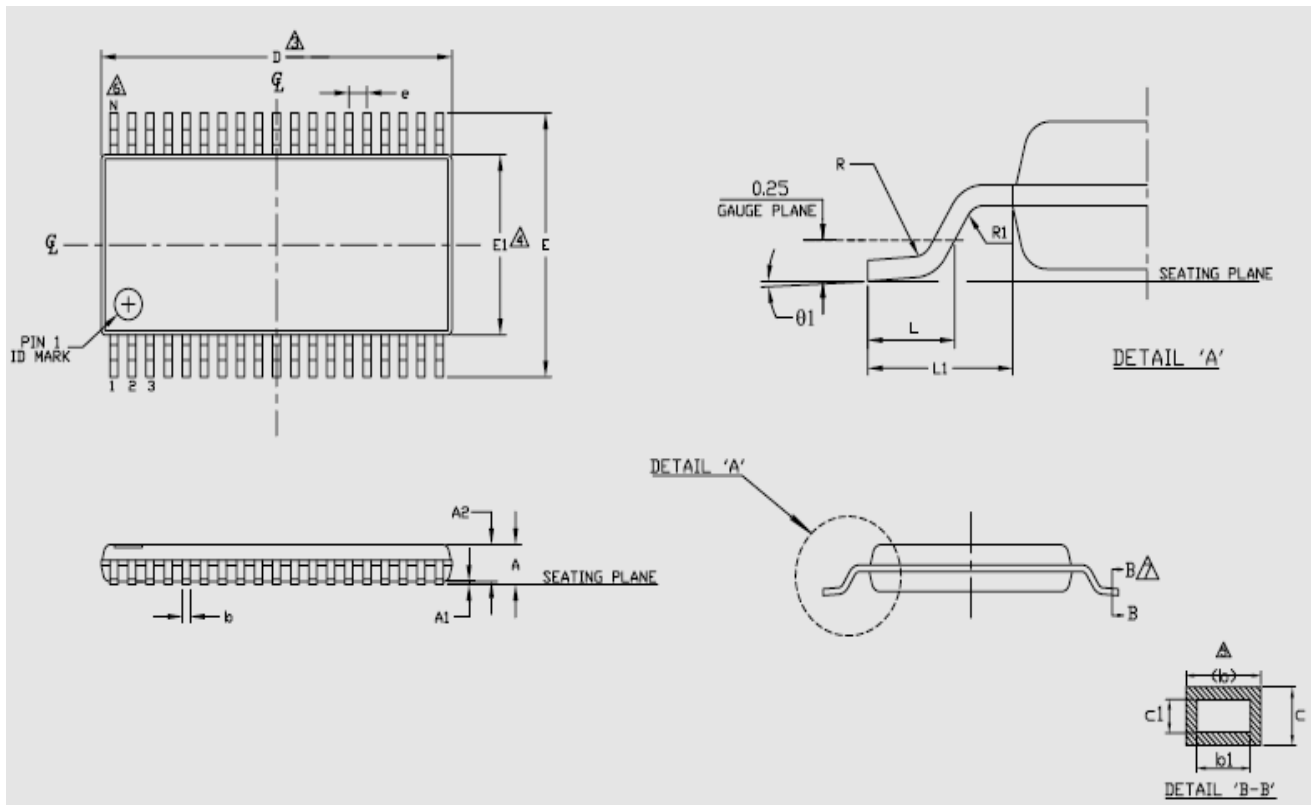

Figure 8-5 DMA terminated by EOT_n

9 Package Parameters

The FT122 is available in two different packages. The FT122T is the TSSOP-28 package option and the FT122Q is the QFN-28 package option. The solder reflow profile for both packages is described in section 9.5.

9.1 TSSOP-28 Package Dimensions



SYMBOL	28L TSSOP		
	MIN	NOM.	MAX
A	—	—	1.20
A1	0.05	—	0.15
A2	0.80	0.90	1.05
D	9.6	9.7	9.8
E1	4.3	4.4	4.5
E	6.2	6.4	6.6
L	0.45	0.60	0.75
R	0.09	—	—
R1	0.09	—	—
b	0.19	—	0.30
b1	0.19	0.22	0.25
c	0.09	—	0.20
c1	0.09	—	0.16
theta1	0°	—	8°
L1	1.0 REF		
e	0.65 BSC		
N	28		
Ref.	Jedec MO-153 Issue C Variation AE		

Figure 9-1 TSSOP-28 Package Dimensions

The FT122T is supplied in a RoHS compliant 28 pin TSSOP package. The package is lead (Pb) free and uses a 'green' compound. The package is fully compliant with European Union directive 2002/95/EC.

This package is nominally 4.4mm x 9.7mm body (6.4mm x 9.7mm including pins). The pins are on a 0.65 mm pitch. The above mechanical drawing shows the TSSOP-28 package.

All dimensions are in millimetres.

9.2 TSSOP-28 Package Markings

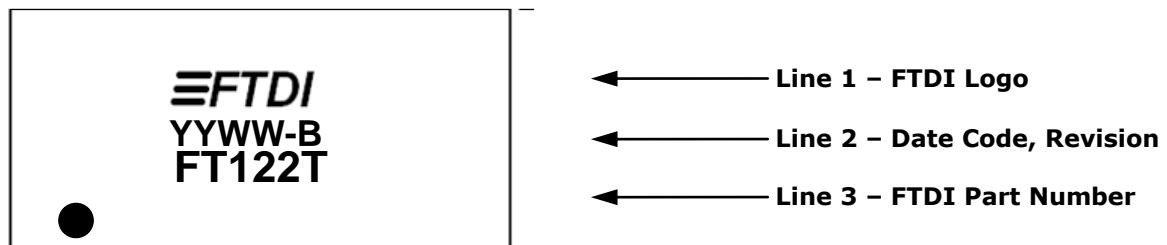

Figure 9-2 TSSOP-28 Package Markings

The date code format is **YYWW** where WW = 2 digit week number, YY = 2 digit year number.

9.3 QFN-28 Package Dimensions

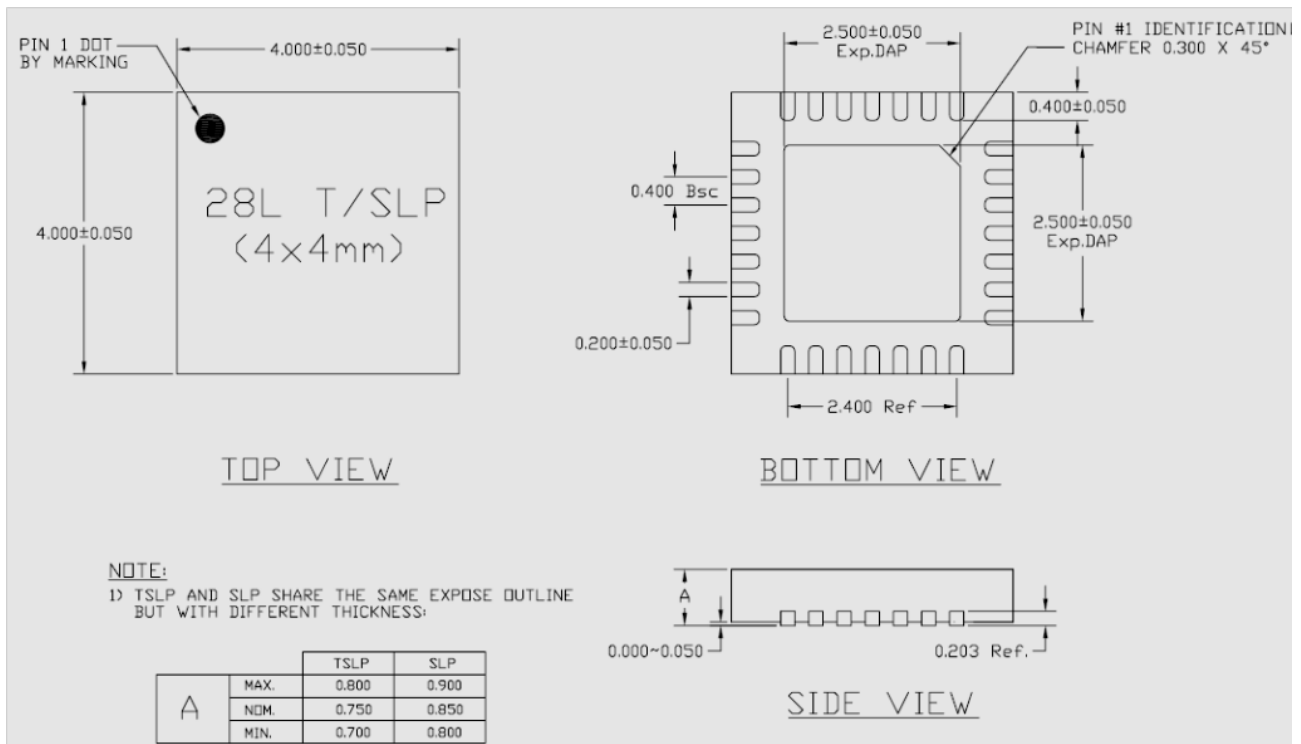

Figure 9-3 QFN-28 Package Dimensions

The FT122Q is supplied in a RoHS compliant leadless QFN-28 package. The package is lead (Pb) free, and uses a 'green' compound. The package is fully compliant with European Union directive 2002/95/EC.

This package is nominally 4.00mm x 4.00mm. The solder pads are on a 0.40mm pitch. The above mechanical drawing shows the QFN-28 package. All dimensions are in millimetres.

The centre pad on the base of the FT122Q is internally connected to GND pin, and can be left unconnected, or connected to ground (recommended).

9.4 QFN-28 Package Markings

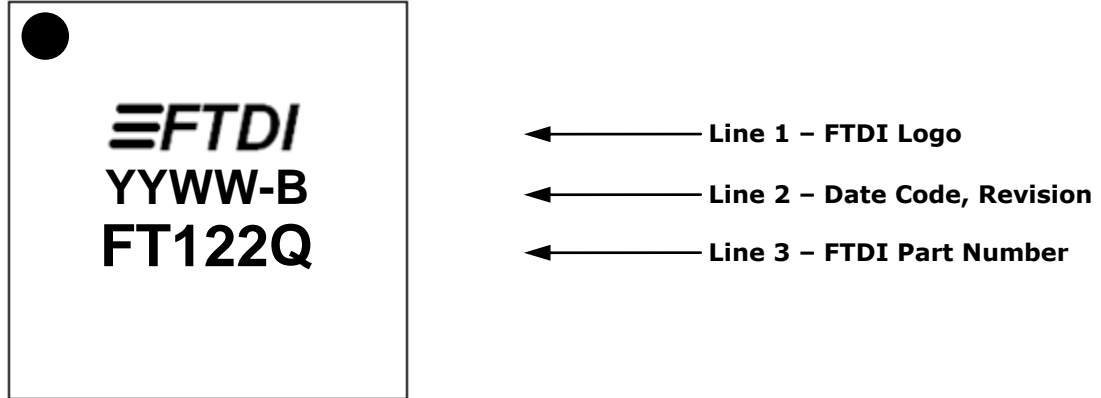

Figure 9-4 QFN-28 Package Markings

The date code format is **YYWW** where WW = 2 digit week number, YY = 2 digit year number.

9.5 Solder Reflow Profile

The FT122 is supplied in Pb free TSSOP-28 and QFN-28 packages. The recommended solder reflow profile for both package options is shown in Figure 9-5.

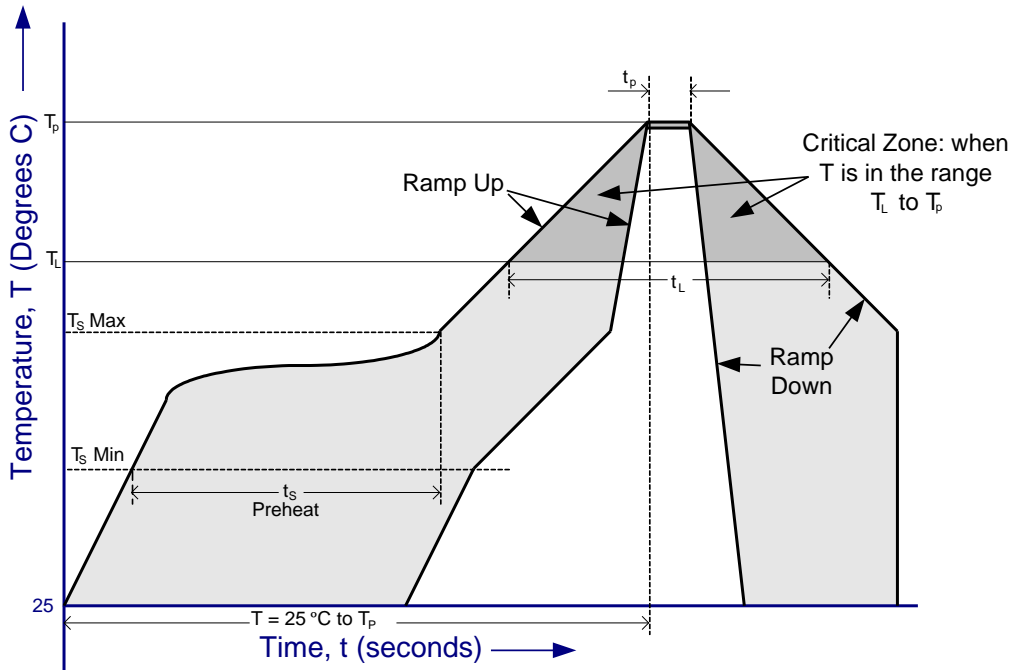

Figure 9-5 FT122 Solder Reflow Profile

The recommended values for the solder reflow profile are detailed in Table 9-1. Values are shown for both a completely Pb free solder process (i.e. the FT122 is used with Pb free solder), and for a non-Pb free solder process (i.e. the FT122 is used with non-Pb free solder).

Profile Feature	Pb Free Solder Process	Non-Pb Free Solder Process
Average Ramp Up Rate (T_s to T_p)	3°C / second Max.	3°C / Second Max.
Preheat - Temperature Min (T_s Min.) - Temperature Max (T_s Max.) - Time (t_s Min to t_s Max)	150°C 200°C 60 to 120 seconds	100°C 150°C 60 to 120 seconds
Time Maintained Above Critical Temperature T_L : - Temperature (T_L) - Time (t_L)	217°C 60 to 150 seconds	183°C 60 to 150 seconds
Peak Temperature (T_p)	260°C	240°C
Time within 5°C of actual Peak Temperature (t_p)	20 to 40 seconds	20 to 40 seconds
Ramp Down Rate	6°C / second Max.	6°C / second Max.
Time for $T = 25^\circ\text{C}$ to Peak Temperature, T_p	8 minutes Max.	6 minutes Max.

Table 9-1 Reflow Profile Parameter Values

10 Contact Information

Head Office – Glasgow, UK

Future Technology Devices International Limited
Unit 1, 2 Seaward Place, Centurion Business Park
Glasgow G41 1HH
United Kingdom
Tel: +44 (0) 141 429 2777
Fax: +44 (0) 141 429 2758

E-mail (Sales) sales1@ftdichip.com
E-mail (Support) support1@ftdichip.com
E-mail (General Enquiries) admin1@ftdichip.com

Branch Office – Hillsboro, Oregon, USA

Future Technology Devices International Limited
(USA)
7130 SW Fir Loop
Tigard, OR 97223
Tel: +1 (503) 547 0988
Fax: +1 (503) 547 0987

E-Mail (Sales) us.sales@ftdichip.com
E-Mail (Support) us.support@ftdichip.com
E-Mail (General Enquiries) us.admin@ftdichip.com

Branch Office – Taipei, Taiwan

Future Technology Devices International Limited
(Taiwan)
2F, No. 516, Sec. 1, NeiHu Road
Taipei 114
Taiwan, R.O.C.
Tel: +886 (0) 2 8791 3570
Fax: +886 (0) 2 8791 3576

E-mail (Sales) tw.sales1@ftdichip.com
E-mail (Support) tw.support1@ftdichip.com
E-mail (General Enquiries) tw.admin1@ftdichip.com

Branch Office – Shanghai, China

Future Technology Devices International Limited
(China)
Room 1103, No.666 West Huaihai Road,
Shanghai, 200052
China
Tel: +86 21 62351596
Fax: +86 21 62351595

E-mail (Sales) cn.sales@ftdichip.com
E-mail (Support) cn.support@ftdichip.com
E-mail (General Enquiries) cn.admin@ftdichip.com

Branch Office – Singapore

Future Technology Devices International Limited (Singapore)
178 Paya Lebar Road
#07-03/04/05
Singapore 409030
Tel: +65 6841 1174
Fax: +65 6841 6071

E-mail (Support) support1@ftdichip.com
E-mail (General Enquiries) admin1@ftdichip.com

Web Site

<http://ftdichip.com>

System and equipment manufacturers and designers are responsible to ensure that their systems, and any Future Technology Devices International Ltd (FTDI) devices incorporated in their systems, meet all applicable safety, regulatory and system-level performance requirements. All application-related information in this document (including application descriptions, suggested FTDI devices and other materials) is provided for reference only. While FTDI has taken care to assure it is accurate, this information is subject to customer confirmation, and FTDI disclaims all liability for system designs and for any applications assistance provided by FTDI. Use of FTDI devices in life support and/or safety applications is entirely at the user's risk, and the user agrees to defend, indemnify and hold harmless FTDI from any and all damages, claims, suits or expense resulting from such use. This document is subject to change without notice. No freedom to use patents or other intellectual property rights is implied by the publication of this document. Neither the whole nor any part of the information contained in, or the product described in this document, may be adapted or reproduced in any material or electronic form without the prior written consent of the copyright holder. Future Technology Devices International Ltd, Unit 1, 2 Seaward Place, Centurion Business Park, Glasgow G41 1HH, United Kingdom. Scotland Registered Company Number: SC136640

Appendix A– References

Useful Application Notes

- http://www.ftdichip.com/Documents/AppNotes/AN_167_FT1248_Parallel_Serial_Interface_Basics.pdf
http://www.ftdichip.com/Support/Documents/TechnicalNotes/TN_100_USB_VID-PID_Guidelines.pdf
http://www.ftdichip.com/Support/Documents/AppNotes/AN_175_Battery%20Charging%20Over%20USB%20with%20FTEX%20Devices.pdf
http://www.usb.org/developers/devclass_docs/BCv1.2_011912.zip

Appendix B - List of Figures and Tables

List of Figures

Figure 2-1 FT122 Block Diagram.....	3
Figure 3-1 TSSOP-28 package schematic symbol	6
Figure 3-2 QFN-28 package schematic symbol.....	6
Figure 8-1 ALE Timing	36
Figure 8-2 Parallel interface timing	37
Figure 8-3 Single cycle DMA timing	38
Figure 8-4 Burst mode DMA timing	38
Figure 8-5 DMA terminated by EOT_n	38
Figure 9-1 TSSOP-28 Package Dimensions.....	39
Figure 9-2 TSSOP-28 Package Markings	40
Figure 9-3 QFN-28 Package Dimensions	41
Figure 9-4 QFN-28 Package Markings.....	42
Figure 9-5 FT122 Solder Reflow Profile	42

List of Tables

Table 3-1 FT122 Pin Description	8
Table 4-1 Interrupt modes.....	10
Table 5-1 Endpoint configuration for EP0 and EP1	11
Table 5-2 Endpoint configuration for EP2	11
Table 5-3 - Example buffer configuration	12
Table 5-4 - Endpoint Maximum Packet Size.....	13
Table 6-1 FT122 default command set.....	15
Table 6-2 enhanced command set	19
Table 6-3 Address Enable Register	19
Table 6-4 Endpoint Enable Register.....	19
Table 6-5 Configuration Register (Byte 1)	20
Table 6-6 Clock Division Factor Register (Byte 2).....	21
Table 6-7 DMA Configuration Register (Byte 1).....	22
Table 6-8 DMA Endpoint Select Register (Byte 2, for Enhanced Mode)	22
Table 6-9 Endpoint Configuration Register	22
Table 6-10 Interrupt Register Byte 1	23



Table 6-11 Interrupt Register Byte 2	23
Table 6-12 Interrupt Register Byte 3 (for Enhanced Mode).....	24
Table 6-13 Interrupt Register Byte 4 (for Enhanced Mode).....	24
Table 6-14 Endpoint Status Register	25
Table 6-15 Endpoint Last Transaction Status Register	25
Table 6-16 Transaction error code	26
Table 6-17 Endpoint Buffer Status Register	27
Table 6-18 Endpoint Control Register	28
Table 6-19 Frame Number LSB Register	29
Table 6-20 Frame Number MSB Register.....	29
Table 6-21 IO Pad Drive Strength Register.....	31
Table 8-1 Absolute Maximum Ratings.....	33
Table 8-2 Operating Voltage and Current.....	34
Table 8-3 digital I/O Pin Characteristics (VCCIO=+3.3V)	34
Table 8-4 digital I/O Pin Characteristics (VCCIO=+2.5V)	34
Table 8-5 digital I/O Pin Characteristics (VCCIO=+1.8V)	35
Table 8-6 USB I/O Pin (DP, USBDM) Characteristics	35
Table 8-7 Parallel Interface IO timing	36
Table 8-8 DMA timing characteristics.....	38
Table 9-1 Reflow Profile Parameter Values	43

Appendix C - Revision History

Document Title: DS_FT122
Document Reference No.: FT_000647
Clearance No.: FTDI# 133
Product Page: <http://www.ftdichip.com/Products/ICs/FT122.htm>
Document Feedback: [Send Feedback](#)

Version Draft	Initial draft	30 th July 2012
Version 1.0	Initial release	1 st October 2012