



# MAX3845/MAX4814E Evaluation Kit

## General Description

The MAX3845/MAX4814E evaluation kit (EV kit) is an assembled demonstration board that provides in-system evaluation of the MAX3845 DVI™/HDMI™ 2:4 TMDs® fanout/buffer and the MAX4814E 2:4 low-frequency switch. The input and output connections are made through Molex DVI and HDMI connectors for direct connection to DVI and HDMI cables.

An AC-to-DC wall-plug power adapter is included to provide power for the board. The board contains DC-DC conversion circuitry to allow operation of the +3.3V-supplied MAX3845 from the +5V DC wall-plug source.

## Ordering Information

PART	TYPE
MAX3845/4814EEVKIT	EV Kit

## Features

- ◆ Full 4-Output Fanout
- ◆ Independent DDC Routing to Any Output from Each Input with Priority to Input 1
- ◆ DVI-I and HDMI Connectors
- ◆ Supports Full 1080p and 1920 x 1200 Resolutions
- ◆ Input 2 Includes MAX3815 for Extended Cable Usage Up to 60 Meters
- ◆ Independent Selection of Preemphasis Level on Each Output
- ◆ All TMDs I/Os Feature 15kV HBM ESD Protection
- ◆ Wall-Plug Power-Supply Operation
- ◆ Fully Assembled and Tested

Evaluates: MAX3845/MAX4814E

## Block Diagram

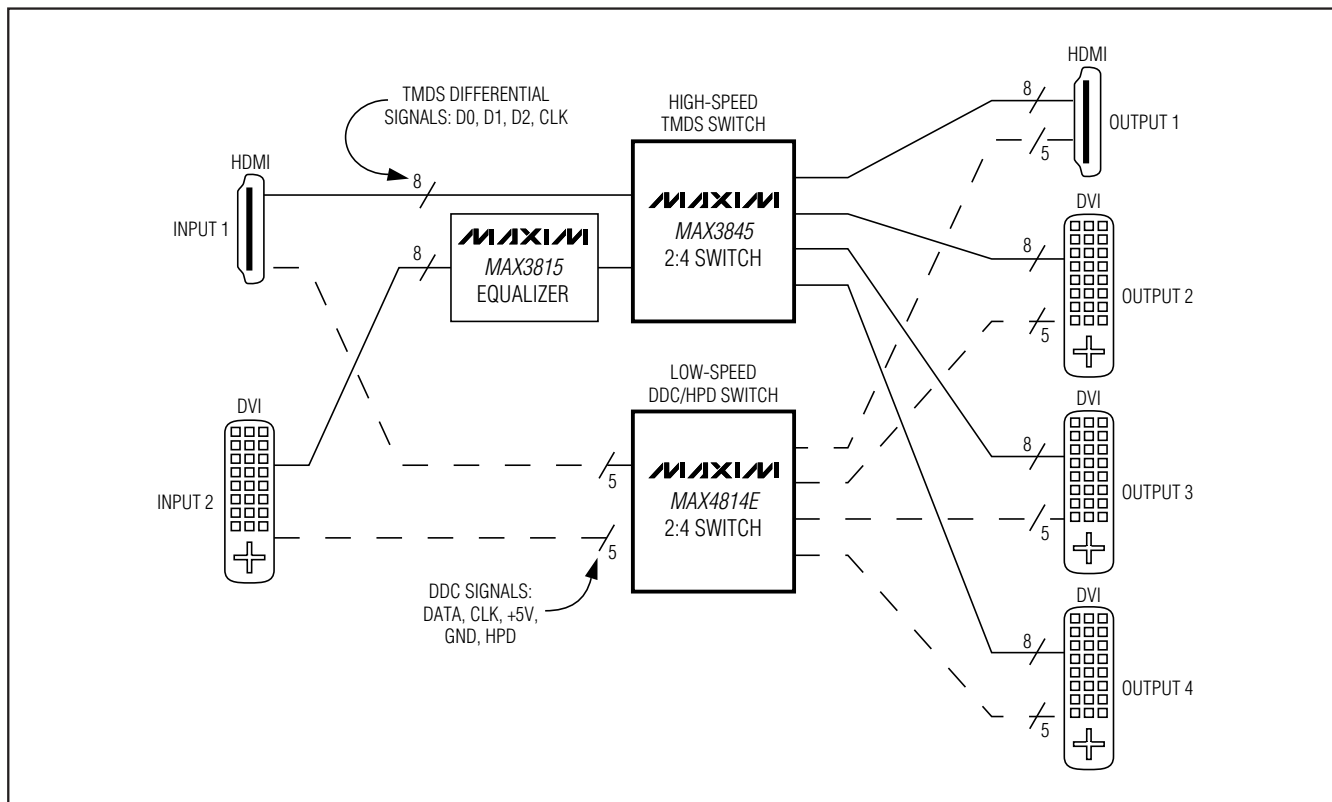

DVI is a trademark of Digital Display Working Group.  
 HDMI is a trademark of HDMI Licensing, LLC.  
 TMDs is a registered trademark of Silicon Image, Inc.



# MAX3845/MAX4814E Evaluation Kit

## Component List

DESIGNATION	QTY	DESCRIPTION
C1–C8, C13	9	0.01 $\mu$ F $\pm$ 10% ceramic capacitors (0402)
C9	1	0.47 $\mu$ F $\pm$ 10% ceramic capacitor (0402)
C10	1	1000pF $\pm$ 10% ceramic capacitor (0402)
C11, C24	2	22 $\mu$ F $\pm$ 10% ceramic capacitors (1206)
C12	1	10 $\mu$ F $\pm$ 10% ceramic capacitor (1206)
C14–C23, C25–C35	21	0.1 $\mu$ F $\pm$ 10% ceramic capacitors (0402)
D3–D6	4	LEDs, dual color
D7–D10	4	Switching diodes
D11	1	LED red
J1, J3	2	HDMI connectors
J2, J4, J5, J6	4	DVI connectors
J9	1	Power jack, 2.1mm
JU1, JU2	2	1 x 2 pin headers (0.1in centers)
JU3	1	1 x 3 pin header (0.1in center)
L1	1	3.3 $\mu$ H inductor Coilcraft MSS5131-332MX
L2	1	Ferrite bead Murata BLM18EG601
Q1	1	PNP transistor Zetex FM591A
R1–R16, R34	17	200 $\Omega$ $\pm$ 5% resistors (0402)
R17–R20	4	47.5k $\Omega$ $\pm$ 1% resistors (0402)
R21–R24, R47	5	100 $\Omega$ $\pm$ 5% resistors (0402)
R29, R30, R32, R33, R35, R36, R44, R45	8	121 $\Omega$ $\pm$ 1% resistors (0402)

DESIGNATION	QTY	DESCRIPTION
R31, R37, R38, R46, R51, R54–R59, R62	12	4.7k $\Omega$ $\pm$ 5% resistors (0402)
R39, R40, R43, R48, R63, R64	6	10k $\Omega$ $\pm$ 5% resistors (0402)
R49	1	2.21k $\Omega$ $\pm$ 1% resistor (0402)
R50	1	1k $\Omega$ potentiometer
R60	1	0 $\Omega$ resistor (0402)
R61	1	OPEN
S1–S8	8	SP3T switches
S9, S10	2	BCD dial switches
SW1–SW4, SW13, SW14, SW19, SW20	8	SPDT switches
TP1–TP10	10	Test points
U1	1	MAX3845UCQ+
U2, U3, U5–U9, U11, U19, U22, U28, U29	12	MAX3208EAUB+
U4	1	74ACT32P
U10	1	MAX1556ETB+
U12	1	MAX3815CCM+
U15–U18	4	Dual BJT transistors Zetex ZXTD6717E6
U20	1	MAX4814EECB+
U24	1	MAX6346XR46+T
None	4	Bumpers
None	3	Shunts
None	1	Wall-plug transformer, 120V AC to 5V DC
None	1	PCB: MAX3845 Board, Rev D

# MAX3845/MAX4814E Evaluation Kit

## Quick Start

For evaluation of the MAX3845 and MAX4814E, configure the board as follows:

- 1) Ensure that jumpers are placed on JU1 and JU2 to allow use of the wall-plug power supply. Shunt the bottom two pins of JU3 to allow direct control of the MAX4814E using BCD switches S9 and S10.
- 2) Plug the power supply into the 120V AC socket and plug the other end into J9. The output LEDs should light up. The Clock Loss LED (D11) should light up red if the MAX3815 is powered (SW20 switch set to the ON position).
- 3) Since the board has back termination resistors installed on the board by default, set the OUTPUT LEVEL switch (SW13) to HIGH. This sets the output swing to the normal HDMI/DVI range even with the back termination resistors in place.
- 4) Connect DVI/HDMI sources and sinks to the inputs and outputs on the EV kit. The LEDs turn green when a powered device is connected to the outputs. This is done by detecting the +5V signal at HOTPLUG.  
**Note:** The DVI connectors on the board allow single-link and dual-link DVI cables with DVI-D (digital only) and DVI-I (digital and analog) connectors, but only digital single-link video passes through the board.
- 5) If a long DVI cable is used to connect to a source, connect it to INPUT 2. This input has the MAX3815 equalizer on it to compensate for high-frequency losses on long cables.
- 6) If a source is connected to INPUT 2, be sure to power up the MAX3815 by switching SW20 to ON and SW19 to AUTO.

- 7) Route the DDC signals through the board using the S9 and S10 rotary switches. Switch S9 routes the DDC signals from input 1, and switch S10 routes the DDC signals from input 2.

**Note:** INPUT 1 DDC has priority, so if INPUT 1 and INPUT 2 are connected to the same output, the DDC connections from INPUT 2 are opened.

- 8) Select the input that you want to appear at outputs 1 to 4 by using the input select switches (S2, S4, S5, S7).
- 9) Select the amount of preemphasis (0dB, 3dB, 6dB) you want to appear at each output using the preemphasis switches (S1, S3, S6, S8).

If manual control of the MAX3815 equalizer is desired, switch SW19 to MANUAL. To increase the amount of equalization (long cables), turn R50 clockwise. To decrease the amount of equalization (short cables), turn R50 counterclockwise. Note that during manual equalization, all three TMDS data channels are set to the same level of equalization.

## ESD Protection

The MAX3845 provides 2kV of ESD protection on all pins. If a higher level of ESD protection is desired, the MAX3208E provides 15kV of ESD protection for DVI and HDMI interfaces. It is designed to provide protection for differential lines while maintaining a low capacitance for minimal effects on signal transmission.

Twelve MAX3208E devices are included in this EV kit to protect all TMDS I/O connections. For samples, contact the Maxim Samples Department at [www.maxim-ic.com/samples](http://www.maxim-ic.com/samples) or call (888) 629-4642.

## MAX3845/MAX4814E Evaluation Kit

Table 1. Adjustment and Control Descriptions (see Quick Start first)

COMPONENT	NAME	FUNCTION
JU3	MODE	Short the bottom two pins of JU3 to control the MAX4814E using the rotary switches S9 and S10. Short the top two pins to control the MAX4814E through I <sup>2</sup> C using TP8 (SDA) and TP9 (SCL).
R50	EQ ADJ	When manual control of the equalizer has been selected using SW19, the level of equalization on the MAX3815 is controlled by R50.
S1, S3, S6, S8	PREEMPHASIS	These switches are used to set the level of preemphasis on the MAX3845's output drivers (0dB, 3dB, or 6dB).
S2, S4, S5, S7	INPUT SELECT	These switches are used to select which input signal appears for each output. The middle position powers down the output.
S9, S10	DDC SWITCHING	These rotary switches are used to connect the DDC signals (SDA, SCL, HOTPLUG, and +5V) from one input to one output.
SW1–SW4	HOTPLUG DETECTION	These switches allow the HOTPLUG signals from the DVI sinks to power up and power down the MAX3845 outputs. To force operation of an output regardless of the HOTPLUG signal, slide the switch down.
SW13	OUTPUT LEVEL	This switch sets all the MAX3845's outputs to increased current drive (HIGH) or normal current drive (LOW). The increased current drive setting allows for 200Ω back termination resistors to be used (installed as default on the board).
SW14	POWER DOWN	This switch powers down input 1 when slid down. Note that any output selected to that input would be powered down as well. The PWRDWN_2 pin is controlled by the loss-of-clock circuit on the MAX3815. If the MAX3815 detects a signal at its RXC_IN input, it powers up input 2 of the MAX3845. If no clock signal is detected, it powers down input 2.
SW19	EQ MODE	Slide the switch up to manually control the level of equalization of the MAX3815. Slide it down to have the MAX3815 automatically control the level of equalization.
SW20	MAX3815 POWER DOWN	This switch powers down the MAX3815 when slid down.
TP2	TEMP SENSE	When the MAX3845 is powered up, the die junction temperature can be estimated by measuring the voltage on TP2 relative to GND. For more information, refer to the MAX3845 data sheet.
TP8	SDA	Connect an I <sup>2</sup> C source to TP8 (SDA) and TP9 (SCL) to control the MAX4814E.
TP9	SCL	

# MAX3845/MAX4814E Evaluation Kit

Evaluates: MAX3845/MAX4814E

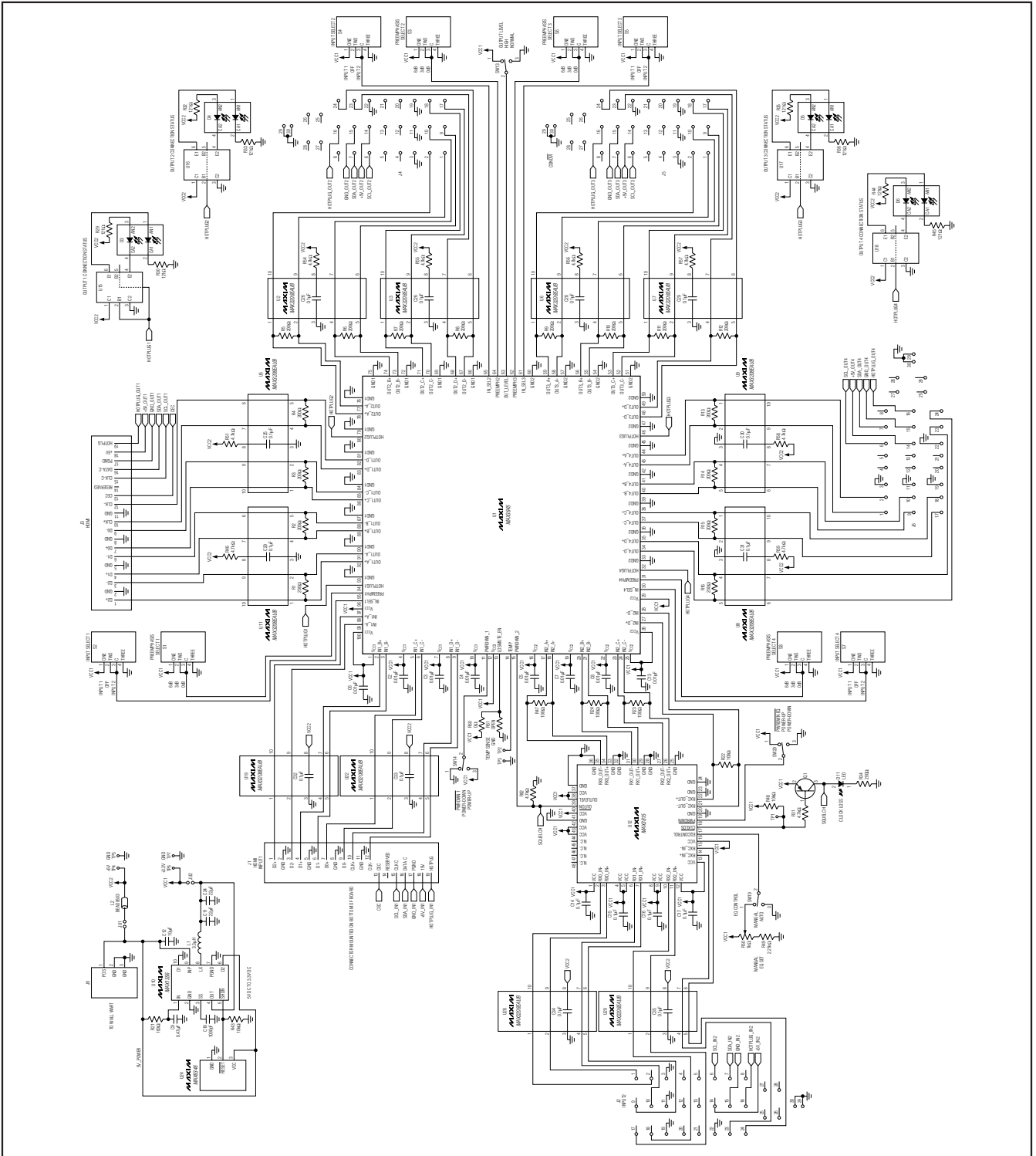

Figure 1. MAX3845/MAX4814E EV Kit Schematic (Sheet 1 of 2)

# MAX3845/MAX4814E Evaluation Kit

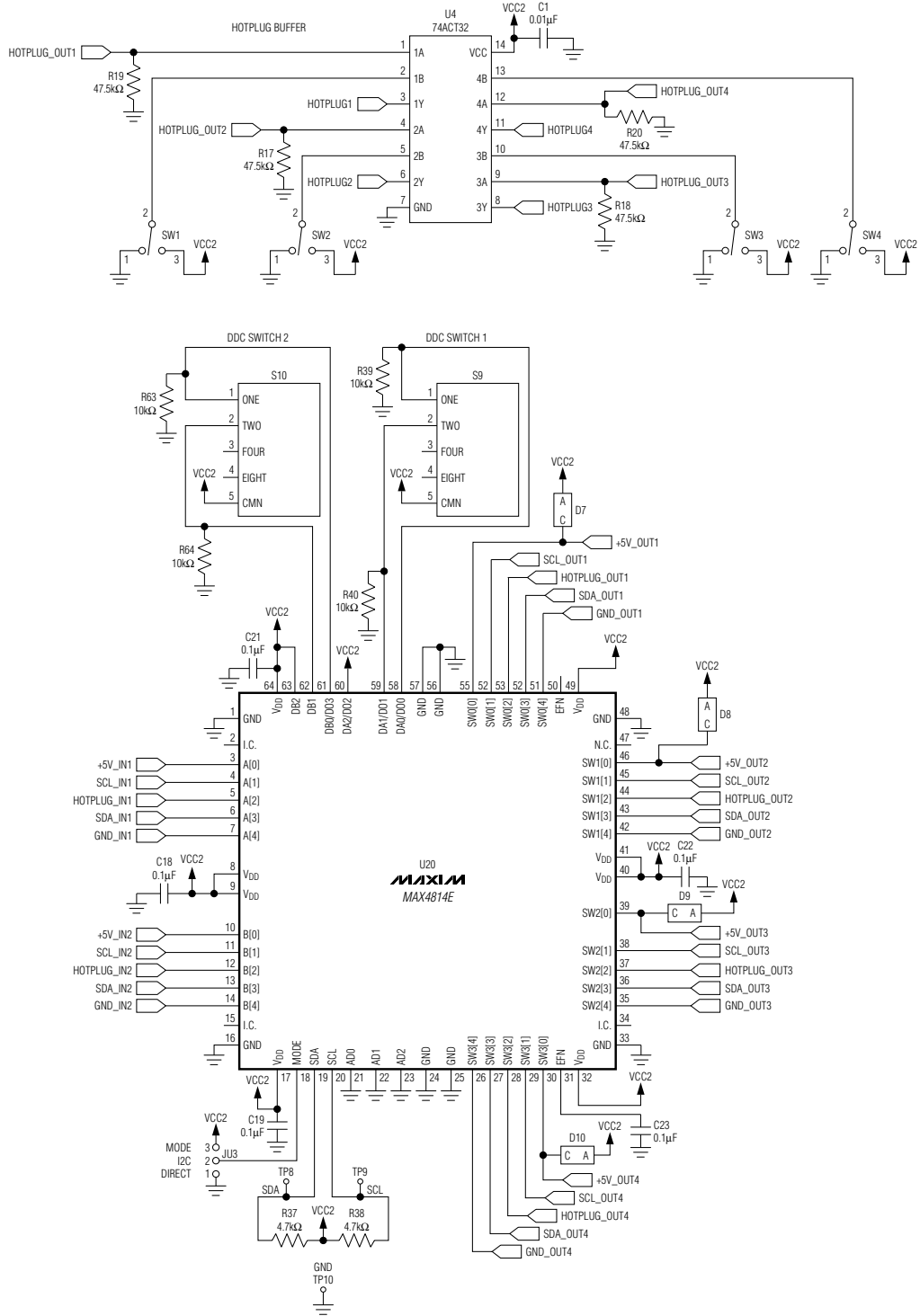

Figure 2. MAX3845/MAX4814E EV Kit Schematic (Sheet 2 of 2)

# MAX3845/MAX4814E Evaluation Kit

Evaluates: MAX3845/MAX4814E

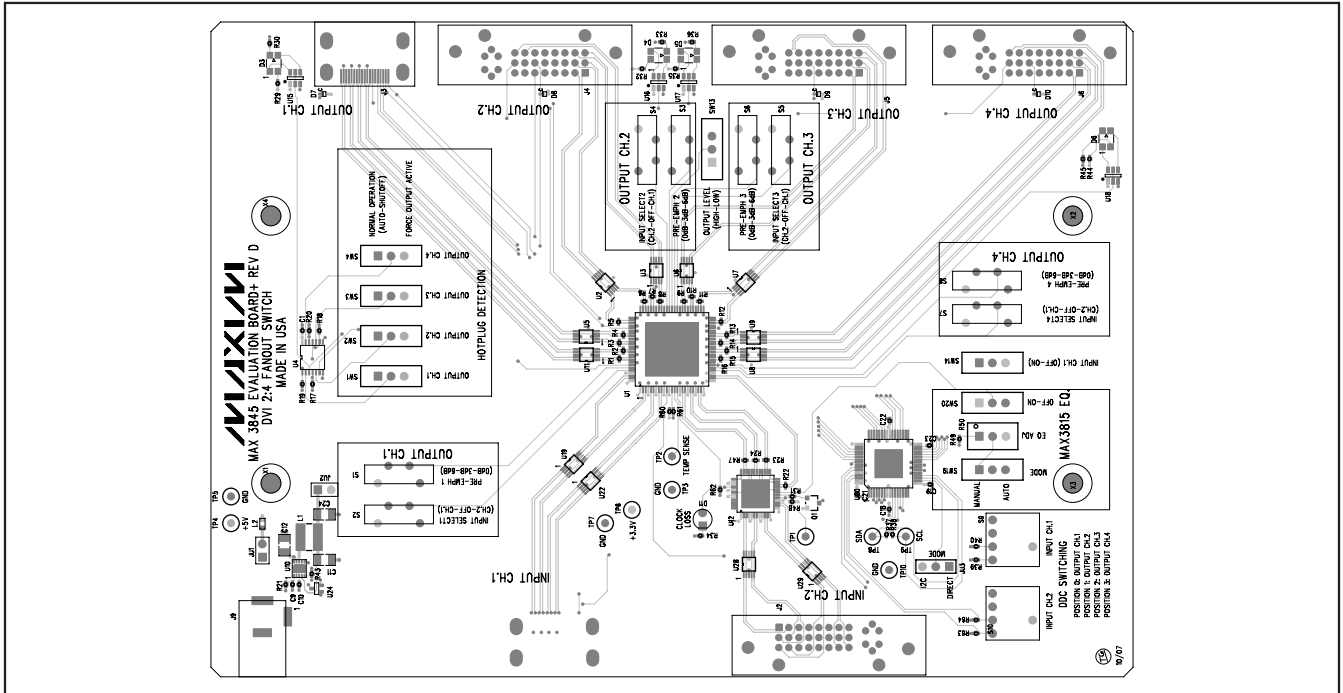

Figure 3. MAX3845/MAX4814E EV Kit Assembly Drawing—Top Side

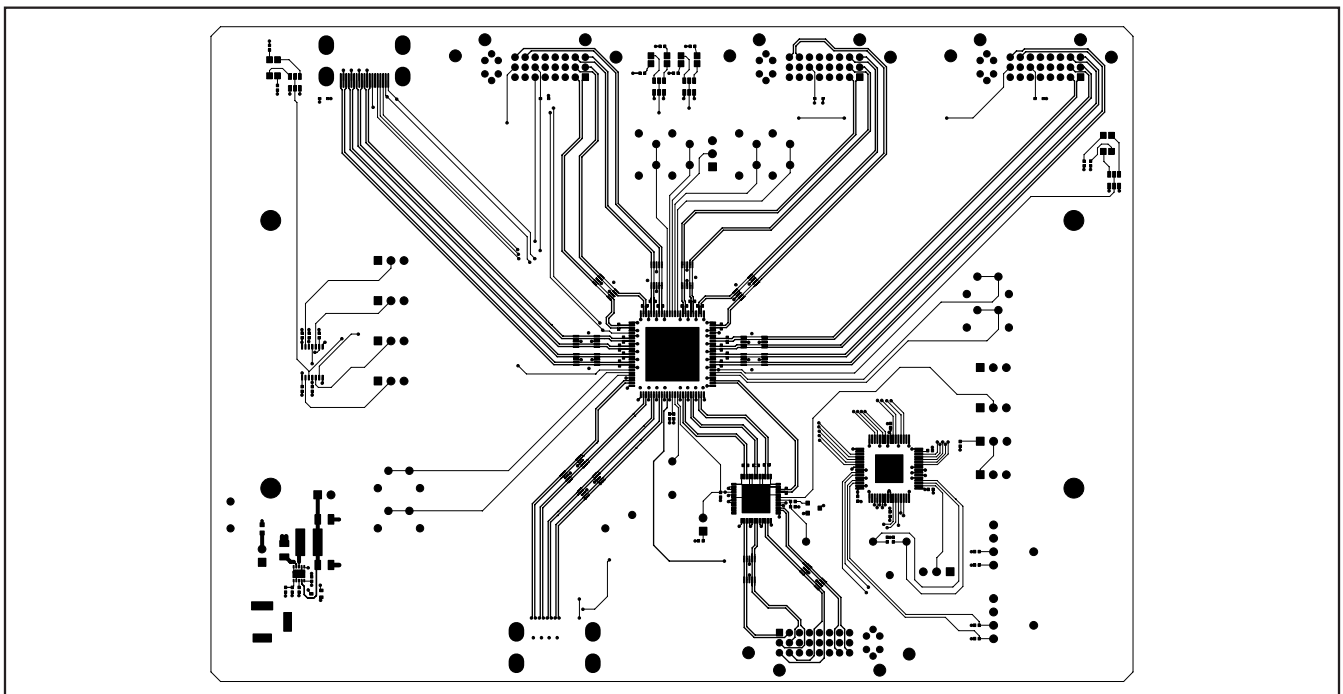

Figure 4. MAX3845/MAX4814E EV Kit Layout—Component Side

# MAX3845/MAX4814E Evaluation Kit

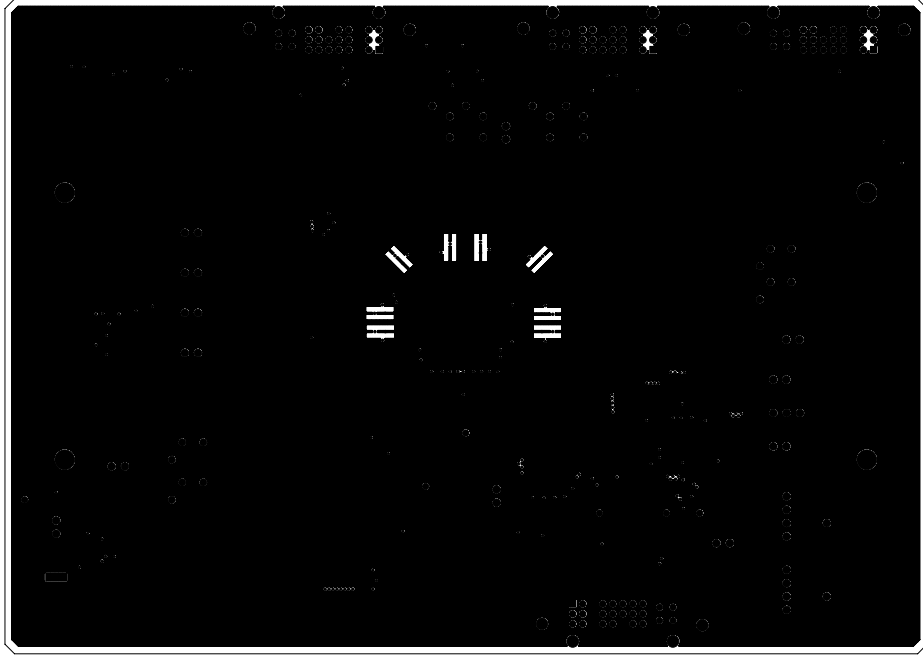

Figure 5. MAX3845/MAX4814E EV Kit Layout—Ground Plane

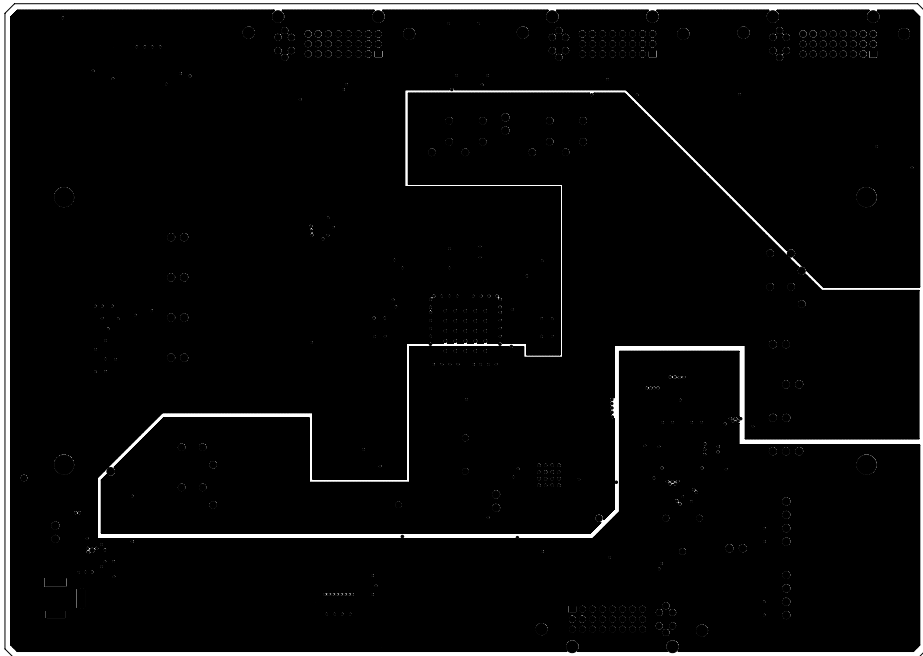

Figure 6. MAX3845/MAX4814E EV Kit Layout—Power Plane



# MAX3845/MAX4814E Evaluation Kit

Evaluates: MAX3845/MAX4814E

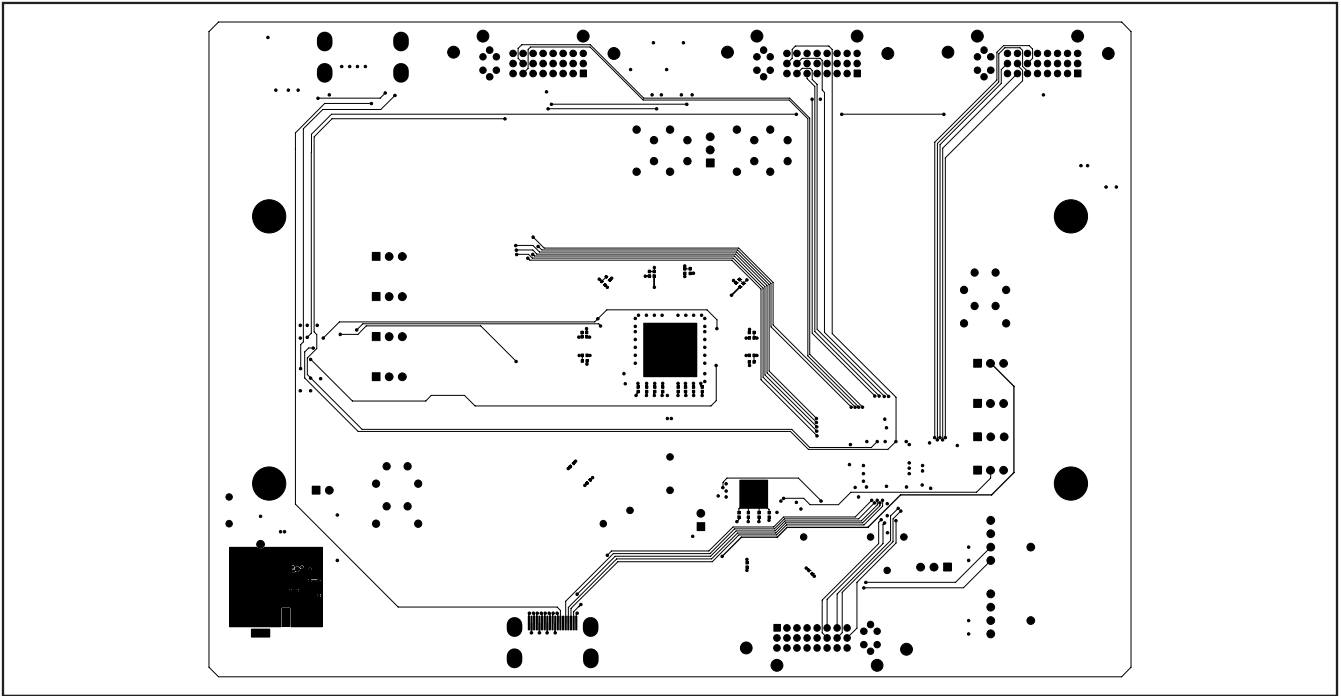

Figure 7. MAX3845/MAX4814E EV Kit Layout—Solder Plane

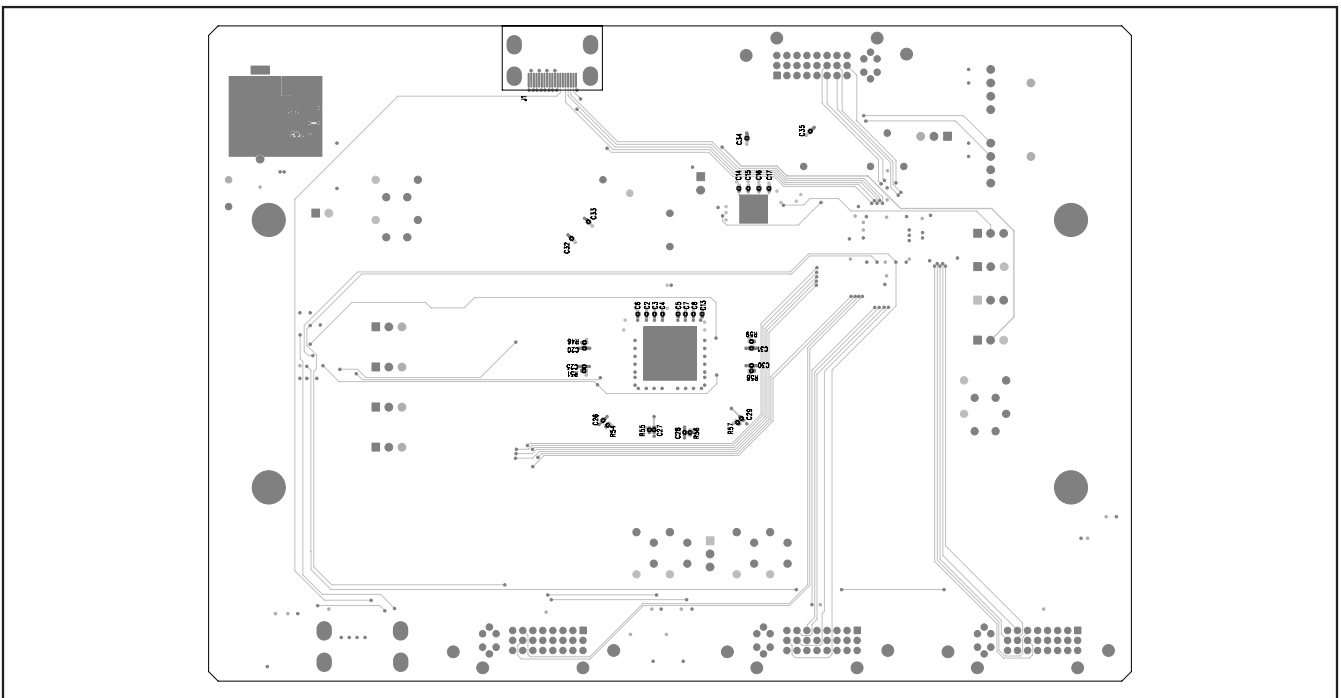

Figure 8. MAX3845/MAX4814E EV Kit Assembly Drawing—Bottom Side

Maxim cannot assume responsibility for use of any circuitry other than circuitry entirely embodied in a Maxim product. No circuit patent licenses are implied. Maxim reserves the right to change the circuitry and specifications without notice at any time.

Maxim Integrated Products, 120 San Gabriel Drive, Sunnyvale, CA 94086 408-737-7600 \_\_\_\_\_ 9