

THIS DRAWING IS UNPUBLISHED. RELEASED FOR PUBLICATION, 19 .
© COPYRIGHT 19 BY AMP INCORPORATED. ALL INTERNATIONAL RIGHTS RESERVED.

LOC	DIST	P	F	ZONE	LTR	DESCRIPTION	DATE	APPD
CE	16				C	REV PER 0A00-0798-03	200CT03	DE/SB

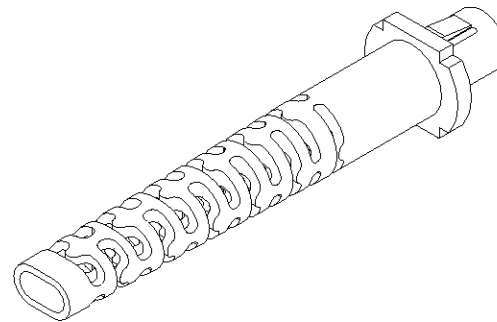
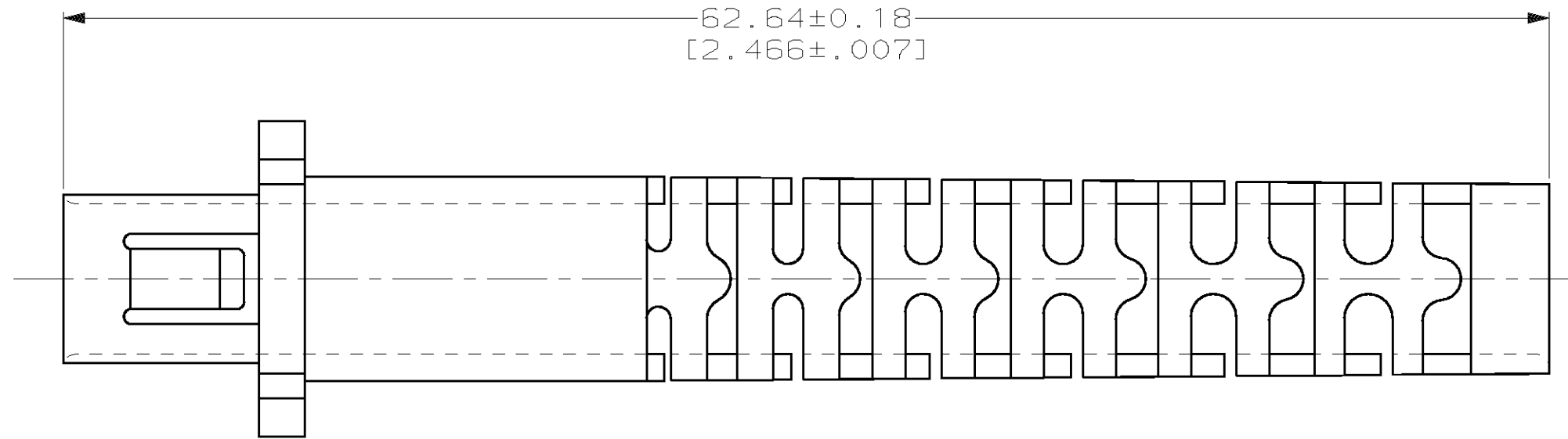
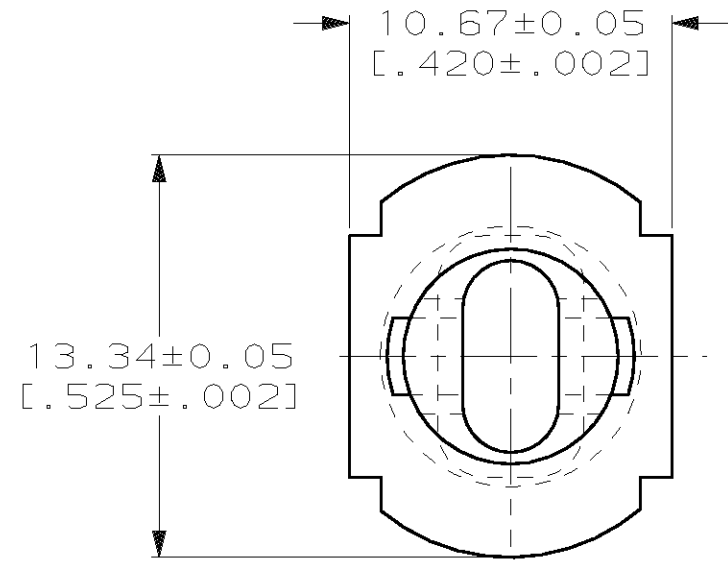

- 1 POLYPROPYLENE MOLDING COMPOUND, COLOR: BEIGE
- 2 POLYPROPYLENE MOLDING COMPOUND, COLOR: DEC LT GRAY
- 3 POLYPROPYLENE MOLDING COMPOUND, COLOR: TANDEM BLACK

OBSOLETE	3	502016-3
OBSOLETE	2	502016-2
	1	502016-1
	MATERIAL	PART NUMBER

DO NOT SCALE PRINT. UNLESS SPECIFIED DIMENSIONS IN mm [INCHES] TOLERANCES ON: 2 PLC DEC ± .010 3 PLC DEC ± - ANGLES ± -	DR 12-16-92 R.HILEMAN CHK 12-16-92 M.PETERSON APPD 12-16-92 M.PETERSON APPD 12-16-92 D.FISHER PRODUCT SPEC - APPLICATION SPEC - WEIGHT -
MATERIAL POLYPROPYLENE	
FINISH SEE TABLE	

AMP AMP Incorporated Harrisburg, PA 17105-3608		
NAME DUPLEX STRAIN RELIEF, LIGHT DUTY DUAL, FIXED SHROUD DUPLEX, OPTIMATE		
SIZE B	CAGE CODE 00779	DRAWING NO C-502016
SCALE 4:1	SHEET 1 OF 1	

THIS DRAWING IS A CONTROLLED DOCUMENT FOR AMP INCORPORATED. IT IS SUBJECT TO CHANGE AND THE CONTROLLING ENGINEERING ORGANIZATION SHOULD BE CONTACTED FOR THE LATEST REVISION.